

# **WILFLEY**<sup>®</sup>

**HEAVY DUTY CENTRIFUGAL PUMPS**

## **Installation, Operation, Maintenance and Storage Manual**

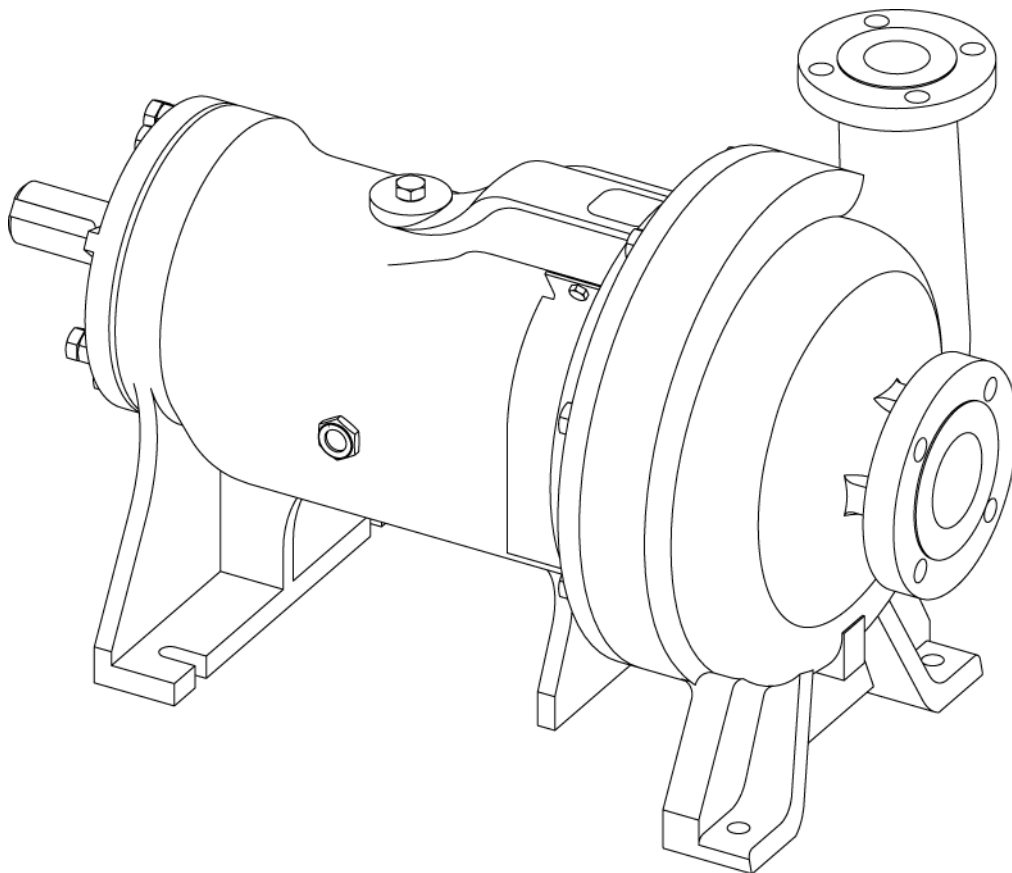

## **S3 Acid Slurry Pump**



## Foreword

This manual contains instructions and guidelines for the assembly of the Wilfley S3 acid slurry pump. There are many factors affecting the successful assembly of a centrifugal pump, which makes it impossible to create a manual that covers all situations. Therefore, the information contained herein is meant to serve only as a general guideline. If detailed questions or problems arise, contact Wilfley or your authorized Wilfley representative.

Supplemental manuals may be required depending on the configuration of the pump.

**It is extremely important that this entire manual be read prior to installation or start-up of the pump.**

Use of the equipment on a service other than what was outlined at the time of purchase could void the warranty, unless Wilfley has been consulted and provided written approval in advance.

To assure proper installation, supervision from an authorized Wilfley representative is recommended.

**A.R. Wilfley and Sons, Inc. shall not be liable for damage or delays caused by a failure to observe the instructions that are contained in this manual.**

**Warranty is only valid when genuine Wilfley parts are used. Contact your authorized Wilfley representative for basic warranty information and before making any changes.**



## Table of Contents

1.0 Safety Considerations .....	7
1.1 Safety Tips .....	8
2.0 General Information .....	8
2.1 Storage Requirements .....	8
2.2 Handling .....	9
3.0 Installation .....	10
3.1 Factory Preliminary Alignment Procedure .....	11
3.2 Recommended Procedure for Baseplate Installation and Final Field Alignment .....	11
3.3 Piping Connection – Suction/Discharge .....	15
3.4 Seal .....	16
3.5 Coupling .....	16
3.6 Coupling Guard .....	16
4.0 Operation .....	16
4.1 Rotation Check .....	16
4.2 Pre Start-Up Checks .....	17
4.3 Start-Up Considerations .....	17
4.4 Starting the Pump and Adjusting Flow .....	18
4.5 Thermal Shock Instructions .....	19
4.6 Operation in Sub-Freezing Conditions .....	19
4.7 Shutdown Considerations .....	19
5.0 Preventive Maintenance .....	19
5.1 General Servicing .....	19
5.2 Periodic Servicing .....	19
5.3 Maintenance Troubleshooting .....	20
6.0 S3 Disassembly and Reassembly .....	24
6.1 Disassembly .....	25
6.2 Cleaning/Inspection .....	26
6.3 Critical Measurement and Tolerances .....	26
6.4 Assembly .....	27
6.5 Setting Impeller Clearance .....	32
6.6 Assembly Troubleshooting .....	33
6.7 Troubleshooting Pump Leaks .....	34
7.0 Lubrication .....	35
8.0 Ordering Parts .....	36
9.0 Special Service .....	36
10.0 Revision History .....	37



## 1.0 Safety Considerations

Like all machinery, centrifugal pumps can be dangerous if used improperly. Any of the following misuses may result in a pump that does not function properly. A pump that does not function properly may be a hazard and could cause damage or injury.

For maximum safety and reliability, use only factory-supplied parts and closely follow all maintenance and operating recommendations and instructions.

Do not change the pumping conditions or installations of a Wilfley pump without consulting A.R. Wilfley and Sons, Inc. first to ascertain if the pump is capable of handling the new conditions and/or fluid. It is not possible to list all the conceivable misuses. Therefore, the following list is not meant to be complete and is provided only as a guide of the types of misuse that can damage a pump and cause injury. The list will also give a good idea of the kinds of misuses that will void any and all warranties.

1. Do not run a pump with the discharge valve closed or below minimum rated flow.
2. Do not run a pump in the reverse direction.
3. Do not start a pump that is "wind-milling" in the reverse direction due to fluid flowing back down the discharge pipe.
4. Do not continue to operate a pump when there are indications that something is rubbing, binding or knocking.
5. Do not continue to run a pump that gives an indication of overheating.
6. Do not operate a pump with the coupling guard removed. Make sure the guard fits snugly around the coupling so there are no openings.
7. Do not operate a pump that is excessively vibrating, surging or making abnormal noise.
8. Do not work on a pump unless the drive system is locked out and the pump is disconnected from the drive system.
9. Do not connect the pump to the drive system without first checking to see that the drive system is running in the correct direction.
10. Do not rely on the factory's alignment of the pump and the drive system. Alignment may have changed during shipment.
11. Do not put a cold liquid in or on a hot pump or a hot liquid in or on a cold pump.
12. Do not hit a pump with any object.
13. Do not use worn or faulty parts.
14. Do not stick hands, arms, legs or any other object into the discharge, suction or any other opening of a pump.
15. Do not weld attachments to the pump.
16. Do not apply external heat to the pump.
17. Do not lift the pump by its case only.
18. Do not examine a pump without using proper eye and face protection.
19. Do not run equipment dry or start the pump without the proper prime (Casing Flooded).
20. Do not exceed the maximum allowable pressure ("Max. P. @ 38°C" as shown on pump nameplate).

The Wilfley S3 acid slurry pump has been designed and manufactured for safe operation. In order to ensure safe operation, it is very important that this manual be read in its entirety prior to installing or operating the pump. Wilfley shall not be liable for physical injury, damage or delays caused by a failure to observe the instructions for installation, operation and maintenance contained in this manual.

Remember that every pump has the potential to be dangerous, because of the following factors:

- Parts are rotating at high speeds.
- High pressures may be present.
- High temperatures may be present.
- Highly corrosive and/or toxic chemicals may be present.

Paying constant attention to safety is always extremely important. However, there are often situations that require special attention. These situations are indicated throughout this book by the following symbols:

## DANGER

DANGER – Immediate hazards that WILL result in severe personal injury or death.

## WARNING

WARNING – Hazards or unsafe practices that COULD result in severe personal injury or death.

## CAUTION

CAUTION - Hazards or unsafe practices that COULD result in minor personal injury, product, or property damage.

**NOTE: ALWAYS COORDINATE REPAIR ACTIVITY WITH OPERATIONS PERSONNEL AND FOLLOW ALL PLANT SAFETY REQUIREMENTS AND APPLICABLE SAFETY AND HEALTH LAWS/REGULATIONS.**

### 1.1 Safety Tips

#### Apparel

- Insulated work gloves when handling hot bearings or using bearing heater
- Heavy work gloves when handling parts with sharp edges, especially impellers
- Safety glasses (with side shields) for eye protection, especially in machine shop areas
- Steel-toed shoes for protection when handling parts, heavy tools, etc.
- Other personal protective equipment to protect against hazardous/toxic fluids

### Maintenance

- Always lockout/tagout power.
- Ensure pump is isolated from system and pressure is relieved before disassembling pump, removing plugs, or disconnecting piping.
- Use proper lifting and supporting equipment to prevent serious injury.
- Observe proper decontamination procedures.
- Know and follow company safety regulations.
- Never apply heat to remove impeller.
- Observe all cautions and warnings highlighted in pump instruction manual.

## 2.0 General Information

### 2.1 Storage Requirements

If the pump is inoperative for a long period of time, it is recommended that the pump be flushed and thoroughly dried to minimize corrosion. It is also advisable to drain the lines and case if there is a possibility of freezing. If the pump is to be stored for more than 15 days, the pump should be rotated once a week to lubricate and to prevent rusting of the bearings.

#### Long-Term Storage

The following guidelines should be followed when the pump or parts will be idle for a period of one month or more.

#### Pump Storage

1. All machined metal surfaces should be coated with a suitable corrosion inhibitor to ensure the integrity of these surfaces at the time of installation.
2. All openings must be covered with suitable covers to protect against contaminants.
3. Storage of the Components and Assemblies should be kept away from all potential vibration sources. (i.e., motors, rotating pumps, engines, etc.). This is to prevent unwanted vibration and possible brinelling of the bearings.



4. Components and assemblies are required to be stored indoors in a dry location. Temperature range should be between 40 degrees and 100 degrees Fahrenheit. If the environment is excessively humid (more than 70%), a suitable desiccant should be used.
5. Pump shafts are required to be rotated 5 full revolutions weekly to prevent brinelling.

## Parts Storage

Not all parts are packaged in a suitable manner from the factory for long-term storage. To ensure satisfactory part performance, all parts must be protected from corrosion and contamination.

## Motor and Seal Storage

Refer to the manufacturer's manuals for storage instructions for these items.

## 2.2 Handling

The following describes how to lift pump components, assembled pumps, or pump, motor and baseplate assemblies. Do not attempt to lift a pump mounted on a baseplate by itself. A pump-motor assembly may only be lifted after it has been installed on a baseplate. Lifting should only be done by trained personnel. Pumps and motors often have integral lifting eyes or eye bolts. These are intended for use in lifting the individual piece of equipment.

# CAUTION

*Do not use eyebolts or cast-in lifting lugs to lift pump, motor and baseplate assemblies.*

Before lifting the equipment, refer to the pump data sheet for the complete assembly weight.

## Pump Components:

*Casing:* Use a choker hitch pulled tight around the discharge nozzle.

*Bearing frame:* Insert a sling between the upper and lower support ribs between the housing barrel and the casing attachment flange. Use a choker hitch when slinging. Caution: make sure there are no sharp edges on the bottom side of the ribs that could cut the sling.

## Bare Pump:

Sling around the pump discharge nozzle and around the outboard end of the bearing housing with separate slings. Choker hitches must be used at both attachment points and pulled tight. Make sure the completion of the choker hitch on the discharge nozzle is toward the coupling end of the pump shaft. The sling lengths should be adjusted to balance the load before attaching the lifting hook.

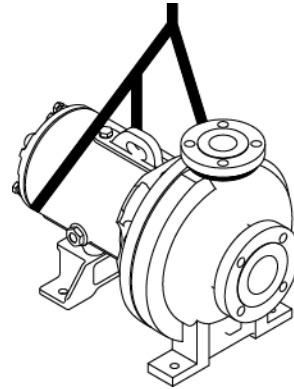

**Bare Pump Lifting**

## Pump, motor and steel baseplate assembly:

Insert lifting S hooks in the lifting lugs and use slings or chains to connect to the lifting eye. Do not use slings through the lifting holes.

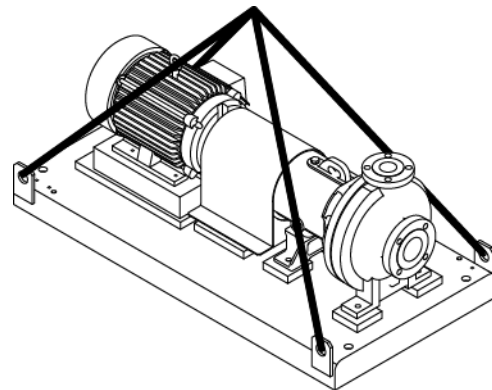

**Complete Pump Assembly Lifting**

## Pump, motor and cast iron or nonmetallic baseplate assembly:

Nonmetallic baseplates can easily be damaged in handling. Be careful to handle the baseplate gently and avoid any shocks. This assembly utilizes a wooden shipping pallet that should be left intact until final installation. The assembly should be forklifted on the pallet to the installation site and then removed only when ready to be installed. Sling around the pump discharge nozzle and around the motor-mounting end of the baseplate. Choker hitches must be used at both attachment points and pulled tight. The sling lengths should be adjusted to balance the load before attaching the lifting hook. Do not use slings through any lifting holes and be careful not to damage the baseplate material.

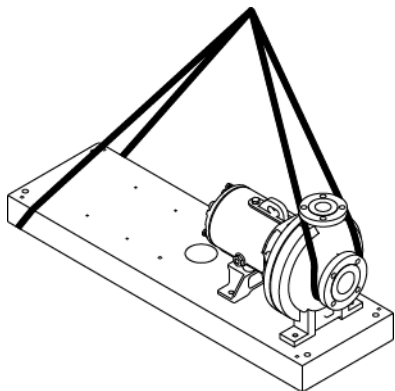

**Pump and Baseplate Lifting**

## 3.0 Installation

### Inspection upon Arrival

Your pump has been carefully inspected and tested prior to shipment to ensure that it meets your requirements. Please inspect the pump upon arrival for any damage that may have occurred during shipment. Report any damage immediately to the carrier.

Leave all shipping covers attached to the pump unit until it is ready for installation. If installation is to be delayed more than 15 days, the pump shaft should be rotated by hand once a week to lubricate the bearings and prevent rusting.

### Choosing Pump Location

The following recommendations may be helpful when choosing the best location for your pump:

1. Locate the pump as close to the liquid source as practical so the suction pipe is short and direct with a minimum of elbows, fittings and valves.
2. Place the pump in a location so the unit is accessible for inspection during operation as well as for maintenance operations involving removal and disassembly.

### Foundation

The foundation should be sufficient to absorb any vibration and to form a permanent, rigid support for the baseplate. This is important to maintain the correct alignment of the direct connected unit. A concrete foundation on a solid base is satisfactory. Foundation bolts of the proper size should be embedded in the concrete located as indicated on the outline drawing.

### Alignment

The pump and motor are aligned at the factory before shipment. Realignment may be necessary after the complete unit has been leveled on the foundation and after the foundation bolts have been tightened. Procedures for checking and aligning the pump components are in section 3.2 of this manual and may also be found in the Hydraulic Institute Standards.

### Piping

Both suction and discharge pipes should be supported independently near the pump so when the flange bolts are tightened no strain will be transmitted to the pump casing. The customer is responsible for proper suction and discharge pipe design and layout to avoid flow induced problems.

### Discharge Piping

A valve should be installed in the discharge line to prevent fluid from flowing back through the pump when it is shut down. The valve should block the discharge line during maintenance.

## Suction Piping

Care should be taken in sizing and locating suction piping to prevent cavitation. A valve should be installed in the suction line to prevent fluid from flowing into the pump when it is shut down.

## Auxiliary Piping – Purge Piping

When required, purge piping is supplied with the pump. An external connection should be made at the pump so purge flow can be varied as required by valving and the pressure can be monitored. Piping fittings and gauges must be corrosion resistant to the fluid being pumped.

## Piping Note

Refer to the Hydraulic Institute Standards for centrifugal pumps for additional piping information.

## 3.1 Factory Preliminary Alignment Procedure

The pump and motor are aligned at the factory to verify the assembly.

## 3.2 Recommended Procedure for Baseplate Installation and Final Field Alignment

### New Grouted Baseplates

1. The pump foundation should be located as close to the source of the fluid to be pumped as practical. There should be adequate space for workers to install, operate and maintain the pump. The foundation should be sufficient to absorb any vibration and should provide a rigid support for the pump and motor. Recommended mass of a concrete foundation should be three times that of the pump, motor and base.
2. Level the pump baseplate assembly with the pump and motor on the baseplate. The proper surfaces to reference when leveling the pump baseplate assembly are the pump suction and discharge flanges. DO NOT stress the baseplate. Do not bolt the suction or discharge flanges of the pump to the piping until the baseplate foundation is completely installed. If equipped, use leveling jackscrews to level the baseplate. If jackscrews are not provided, shims and wedges should be used. Check for

levelness in both the longitudinal and lateral directions. Shims should be placed at all base anchor bolt locations and in the middle edge of the base if the base is more than five feet long. Do not rely on the bottom of the baseplate to be flat. Standard baseplate bottoms are not machined, and it is not likely that the field-mounting surface is flat.

3. After leveling the baseplate, tighten the anchor bolts. If shims were used, make sure that the baseplate was shimmed near each anchor bolt before tightening. Failure to do this may result in twisting of the baseplate, which could make it impossible to obtain final alignment. Check the level of the baseplate to make sure that tightening the anchor bolts did not disturb the level of the baseplate. If the anchor bolts did change the level, adjust the jackscrews or shims as needed to level the baseplate. Continue adjusting the jackscrews or shims and tightening the anchor bolts until the baseplate is level.
4. Check initial alignment between the pump and driver with a straight edge and correct as needed.
5. Grout the baseplate. A nonshrinking grout should be used. Make sure that the grout fills the area under the baseplate. After the grout has cured, check for voids and repair them. Jackscrews, shims and wedges should be removed from under the baseplate at this time. If they were to be left in place, they could rust, swell and cause distortion in the baseplate.
6. Run piping to the suction and discharge of the pump. There should be no piping loads transmitted to the pump after connection is made. Recheck the alignment to verify that there are no significant loads.
7. Use the following procedure and set up the final alignment between the pump and driver.

Step 8 follows the alignment section.

## Alignment Procedure

# WARNING

Before beginning any alignment procedure make sure driver power is locked out

The points at which alignment is checked and adjusted are:

- **Initial Alignment** is done prior to operation when the pump and the driver are at ambient temperature.
- **Final Alignment** is done after operation when the pump and driver are at operating temperature.

Adding or removing shims under the feet of the motor and pump and by shifting equipment horizontally as needed achieves alignment.

**NOTE:** Proper alignment is the responsibility of the installer and user of the unit, not Wilfley.

Accurate alignment of the equipment must be obtained and sustained. Trouble-free operation can be accomplished by following the proper procedures.

## Alignment Checks

### Initial Alignment (Cold Alignment)

- Before Grouting Baseplate – To ensure alignment can be obtained.
- After Grouting Baseplate – To ensure no changes have occurred during the grout process.
- After Connecting Piping – To ensure pipe strains haven't altered alignment. If changes have occurred, alter piping to remove pipe strains on pump flanges.

### Final Alignment (Hot Alignment)

- After First Run – To obtain correct alignment when both pump and driver are at operating temperature. Thereafter, alignment should be checked periodically in accordance with plant operating procedures.

### Alignment Criteria

Good alignment is achieved when the dial indicator readings are specified in the alignment procedure as 0.002 in (0.05 mm) Total Indicated Reading (T.I.R.) or less when the pump and driver are at operating temperature (Final Alignment).

During the installation phase, however, it is necessary to set the parallel alignment in the vertical direction to a different criterion due to differences in expansion rates of the pump and driver. Recommended preliminary (cold) settings for electric motor-driven pumps based on different pumpage temperatures are listed in the following table.

Pumpage Temp	Set Driver Shaft
50°F (10°C)	0.002 in (0.05 mm) LOW
122°F (50°C)	0.001 in (0.03 mm) HIGH
302°F (150°C)	0.005 in (0.12 mm) HIGH

### Dual-Dial Indicator Alignment Setup

1. Mount two dial indicators on one of the coupling halves *P* so they contact the other coupling half *M*.
2. Check setting of indicators by rotating coupling half *P* to ensure indicators stay in contact with coupling half *M* but do not bottom out. Adjust indicators accordingly.

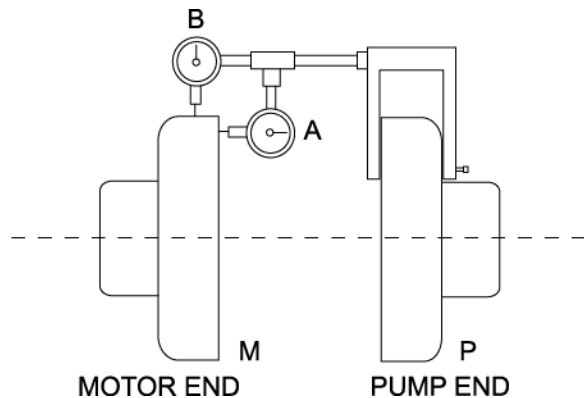

**Alignment – Two-Dial Indicator Method**

## Measurement

1. To ensure accuracy of indicator readings, always rotate both coupling halves together so indicators contact the same point on coupling half *M*. This will eliminate any measurement problems due to runout on coupling half *M*.
2. Take indicator measurements with driver feet hold-down bolts tightened. Loosen hold-down bolts prior to making alignment corrections.
3. Take care not to damage indicators when moving driver during alignment corrections.

## Angular Alignment

A unit is in angular alignment when indicator *A* (Angular Indicator) does not vary by more than 0.002 in (0.05 mm) as measured at four points 90° apart.

### Vertical Correction (Top to Bottom)

1. Zero indicator *A* at top dead center (12 o'clock) of coupling half *M*.
2. Rotate indicators to bottom dead center (6 o'clock). Observe needle and record reading.
3. **Negative Reading** – The coupling halves are further apart at the bottom than the top. Correct by either raising the driver feet at the shaft end (add shims) or lowering the driver feet at the other end (remove shims).  
  
**Positive Reading** – The coupling halves are closer at the bottom than at the top. Correct by either lowering the driver feet at the shaft end (remove shims) or raising the driver feet at the other end (add shims).
4. Repeat steps 1–3 until indicator *A* reads 0.002 in (0.05 mm) or less.

### Horizontal Correction (Side to Side)

1. Zero indicator *A* on the left side of coupling half *M*, 90° from top dead center (9 o'clock).
2. Rotate indicators through top dead center to the right side, 180° from the start (3 o'clock). Observe needle and record reading.

3. **Negative Reading** – The coupling halves are further apart on the right side than the left. Correct by either sliding the shaft end of the driver to the left or the other end to the right.

**Positive Reading** – The coupling halves are closer together on the right side than the left. Correct by either sliding the shaft end of the driver to the right or the other end to the left.

4. Repeat steps 1–3 until indicator *A* reads 0.002 in (0.05 mm) or less.
5. Re-check both horizontal and vertical readings to ensure adjustment of one did not disrupt the other.

## Parallel Alignment

A unit is in parallel alignment when indicator *B* (Parallel Indicator) does not vary by more than 0.002 in (0.05mm) as measured at four points 90° apart at operating temperature. Note the preliminary vertical cold setting table for values.

### Vertical Correction (Top to Bottom)

1. Zero indicator *B* at top dead center of coupling (12 o'clock) half *M*.
2. Rotate indicator to bottom dead center (6 o'clock). Observe needle and record reading.
3. **Negative Reading** – Coupling half *P* is lower than coupling half *M*. Correct by adding shims of thickness equal to half of the indicator reading under each driver foot.

**Positive Reading** – Coupling half *P* is higher than coupling half *M*. Correct by removing shims of thickness equal to half of the indicator reading from each driver foot.

**NOTE: Equal amounts of shims must be added to or removed from each driver foot. Otherwise the vertical angular alignment will be affected.**

4. Repeat steps 1–3 until indicator *B* reads within 0.002 in (0.05 mm) or less when hot, or per the vertical cold setting table values.

## Horizontal Correction (Side to Side)

1. Zero indicator *B* on the left side of the coupling half *M*, 90° from top dead center (9 o'clock).
2. Rotate indicators through top dead center to the right side, 180° from the start (3 o'clock). Observe needle and record reading.
3. **Negative Reading** – Coupling half *M* is to the left of coupling half *P*. Correct by sliding driver evenly in the appropriate direction.

**Positive Reading** – coupling half *M* is to the right of coupling half *P*. Correct by sliding the driver evenly in the appropriate direction.

**NOTE: Failure to slide motor evenly will affect horizontal angular correction.**

4. Repeat steps 1–3 until indicator *B* reads 0.002 in (0.05 mm) or less.
5. Re-check both horizontal and vertical readings to ensure adjustment of one did not disrupt the other. Correct as necessary.

## Complete Alignment

A unit is in complete alignment when both indicators *A* (angular) and *B* (parallel) do not vary by more than 0.002 in (0.05 mm) as measured at four points 90° apart.

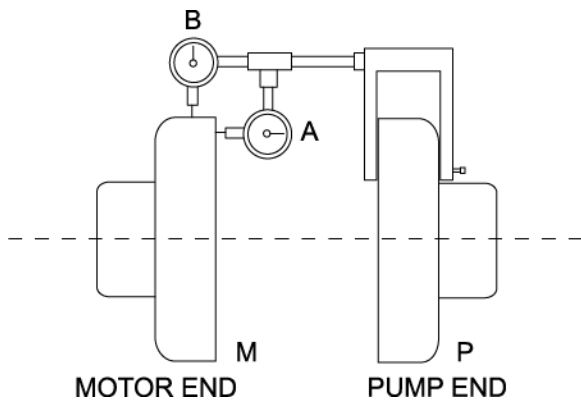

**Alignment – Two-Dial Indicator Method**

## Vertical Correction (Top to Bottom)

1. Zero indicators *A* and *B* at top dead center (12 o'clock) of coupling half *M*.
2. Rotate indicator to bottom dead center (6 o'clock). Observe the needles and record the readings.
3. Make corrections as outlined previously.

## Horizontal Correction (Side to Side)

1. Zero indicators *A* and *B* on the left side of coupling half *M*, 90° from top dead center (9 o'clock).
2. Rotate indicators through top dead center to the right side, 180° from the start (3 o'clock). Observe the needle, measure and record the reading.
3. Make corrections as outlined previously.
4. Re-check both vertical and horizontal readings to ensure adjustment of one did not disrupt the other. Correct as necessary.

**NOTE: With experience, the installer will understand the interaction between angular and parallel and will make corrections appropriately.**

## Laser Alignment

This method can be used in place of the dual dial indicator method. Please follow the instructions given by the laser equipment manufacturer.

## Alignment Troubleshooting

Operate the pump for at least an hour or until it reaches final operating temperature. Shut the pump down and recheck alignment while the pump is hot. Piping thermal expansion may change the alignment. Realign pump as necessary. See table below for possible alignment issues.

PROBLEM	POSSIBLE CAUSE	RECOMMENDED REMEDY
Can't obtain horizontal (side to side) alignment, angular or parallel.	Driver feet bolt bound.	Loosen pump hold down bolts and slide pump and driver until horizontal alignment is achieved.
	Baseplate not leveled properly, possibly twisted.	Determine which corner(s) of the baseplate are high or low and remove or add shims at the appropriate corner(s) and realign.
Can't obtain vertical (top to bottom) alignment, angular or parallel.	Baseplate not leveled properly, possibly bowed.	Determine if center of baseplate should be raised or lowered and correct by evenly adding or removing shims at the center of the baseplate.

## Existing Grouted Baseplates

When a pump is being installed on an existing grouted baseplate, the procedure is somewhat different from the previous section "New Grouted Baseplates".

1. Mount the pump on the existing baseplate.
2. Level the pump by putting a level on the discharge flange. If not level, adjust the foot piece by adding or deleting shims between the bearing frame and baseplate.
3. Check initial alignment between the pump and driver with a straight edge and correct as needed.
4. Run piping to the suction and discharge flanges of the pump.
5. Perform final alignment.
6. Recheck alignment after pump is hot.

## 3.3 Piping Connection – Suction/Discharge

All piping must be independently supported, accurately aligned and preferably connected to the pump by a short length of flexible piping. The pump should not have to support the weight of the pipe or compensate for misalignment. It should be possible to install suction and discharge bolts through mating flanges without pulling or prying either of the flanges. All piping must be airtight. Pumps may air-bind if air is allowed to leak into the piping. If the pump flange(s) have tapped holes, select flange fasteners with thread engagement at least equal to the fastener diameter but that do not bottom out in the tapped holes before the joint is tight.

## WARNING

### Piping Forces:

Take care during installation and operation to minimize pipe forces and/or moments on the pump casing.

### Suction Piping

To avoid NPSH and suction problems, suction pipe sizes must be the same or greater than the pump suction connection. **Never** use pipe or fittings on the suction that are smaller in diameter than the pump suction size.

The ideal piping configuration should have a minimum of 10 pipe diameters between the source and the pump suction. In most cases, horizontal reducers should be eccentric and mounted with the flat side on top or up with a maximum of one pipe size reduction. Never mount eccentric reducers with the flat side down. Horizontally mounted concentric reducers should not be used if there is any possibility of entrained air in the process fluid. Vertically mounted concentric reducers are acceptable. In applications where the fluid is completely de-aerated and free of any vapor or suspended solids, concentric reducers are preferable to eccentric reducers.

Avoid the use of throttling valves and strainers in the suction line. Start-up strainers must be removed shortly after startup. When the pump is installed below the source of supply, a valve should be installed in the suction line to isolate the pump and

to permit pump inspection and maintenance. However, never place a valve directly on the suction nozzle of the pump. Refer to the Centrifugal Pump IOM Section of the Hydraulic Institute Standards for additional recommendations on suction piping.

### Discharge Piping

Install a valve in the discharge line. This valve is required for regulating flow and/or to isolate the pump for inspection and maintenance.

## WARNING

*A rapidly closing discharge valve can cause a damaging pressure surge. A dampening arrangement should be provided in the piping.*

### Pump and Shaft Alignment Check

After connecting piping, rotate the pump drive shaft clockwise (view from motor end) several complete revolutions by hand to be sure there is no binding and that all parts are free. Recheck shaft alignment. If piping caused unit to be out of alignment, correct piping to relieve strain on the pump.

### 3.4 Seal

It is Wilfley's standard practice to install the seal in the pump prior to shipment. Specific order requirements may specify that the seal be shipped separately, or none be supplied. It is the pump installer's responsibility to determine if a seal was installed. If a seal was supplied but not installed, use

### 3.5 Coupling

The coupling should be installed as advised by the coupling manufacturer. Pumps are shipped without the spacer installed. If the spacer has been installed to facilitate alignment, then it must be removed prior to checking rotation. Remove protective material from the coupling and any exposed portions of the shaft before installing the coupling.

### 3.6 Coupling Guard

## WARNING

*Power must **never** be applied to the driver when the coupling guard is not installed.*

Wilfley coupling guards are safety devices intended to protect workers from inherent dangers of the rotating pump shaft, motor shaft and coupling. It is intended to prevent entry of hands, fingers or other body parts into a point of hazard by reaching through, over, under or around the guard. No standard coupling guard provides complete protection from a disintegrating coupling. Wilfley cannot guarantee its guards will completely contain an exploding coupling.

The Wilfley coupling guard conforms to the U.S.A. standard ASME B15.1, "Safety Standard for Mechanical Power Transmission Apparatus."

### 4.0 Operation

#### 4.1 Rotation Check

## CAUTION

**A direction arrow is cast on the front of the casing. Make sure the motor rotates in the same direction before coupling the motor to the pump.**

*It is absolutely essential that the rotation of the motor be checked before connecting the shaft coupling. Incorrect rotation of the pump, for even a short time, can dislodge the impeller, which may cause serious damage to the pump. All Wilfley S3 pumps turn clockwise as viewed from the motor end, or conversely, counterclockwise when viewed from the suction end*

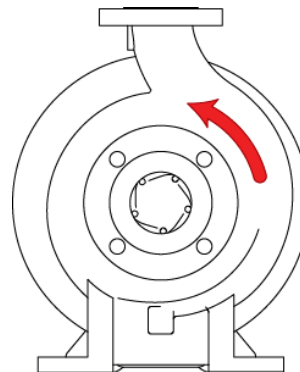

**Pump with Rotation Direction Arrow**



## 4.2 Pre Start-Up Checks

Prior to starting the pump, it is essential that the following checks be made.

- Visually check all main and auxiliary piping to ensure that all connections have been properly made.
- Check voltage, fuse, starter amperage ratings and frequency on the motor nameplate against the electrical supply characteristics.
- Visually inspect all electrical connections to the motor and control circuit.
- Check the rotation of the motor by momentarily starting the motor with motor disconnected from the pump assembly. Direction of rotation must be as shown by the arrow on the pump case and the direction of rotation plate on the top of the frame. Starting or running pump backwards will cause damage.
- Pump and motor are properly secured to the baseplate.
- All fasteners tightened to the correct torques.
- Coupling guard in place and not rubbing.
- Impeller clearance setting.
- Bearing lubrication.
- Pump instrumentation is operational.
- Pump is primed.

As a final step in preparation for operation, it is important to rotate the shaft by hand to be certain that all rotating parts move freely and that there are no foreign objects in the pump casing.

### Starting

Before starting the pump, it is advisable to have the pump casing and suction line filled with liquid. It is normal to have the discharge valve momentarily closed when the pump is started since much less horsepower is required under these conditions.

**DO NOT OPERATE THE PUMP IN A DEAD-HEAD (NO FLOW) CONDITION.**

## 4.3 Start-Up Considerations

### Ensuring Proper NPSHA

Net Positive Suction Head – Available (NPSHA) is the measure of the energy in a liquid above the vapor pressure. It is used to determine the likelihood that a fluid will vaporize in the pump. It is critical because a centrifugal pump is designed to pump a liquid, not a vapor. Vaporization in a pump will result in damage to the pump, deterioration of the Total Differential Head (TDH) and possibly a complete stoppage of pumping.

Net Positive Suction Head – Required (NPSHR) is the decrease of fluid energy between the inlet of the pump and the point of lowest pressure in the pump. This decrease occurs because of friction losses and fluid accelerations in the inlet region of the pump and, particularly, accelerations as the fluid enters the impeller vanes. The value for NPSHR for the specific pump purchased is given in the pump data sheet and on the pump performance curve. For a pump to operate properly the NPSHA must be greater than the NPSHR. Good practice dictates that this margin should be at least 3 ft (1 m) or 20%, whichever is greater.

## CAUTION

*Ensuring that NPSHA is larger than NPSHR by the suggested margin will greatly enhance pump performance and reliability. It will also reduce the likelihood of cavitation, which can severely damage the pump.*

### Minimum Flow

Minimum continuous stable flow is the lowest flow at which the pump can operate satisfactorily. Pumps may be operated at lower flows, but it must be recognized that the pump operating life may be significantly reduced. For example, vibration may exceed normal industrial standards. The size of the pump, the energy absorbed and the liquid pumped are some of the considerations in determining the minimum flow. The allowable operating range of the pump is in accordance to the severity of the slurry duty. The Model S3 pump covers the following range classified by specific gravity and average particle size.

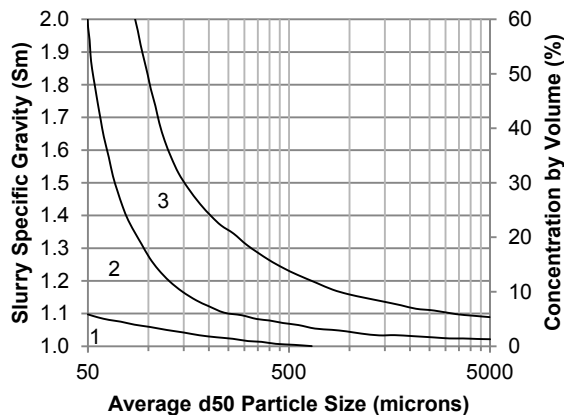

Parameter	Service Zone		
	1	2	3
Max. Discharge Velocity	40 ft/s (12.2 m/s)	32 ft/s (9.8 m/s)	27 ft/s (8.2 m/s)
Max. Impeller Peripheral Speed	8,500 ft/m (43 m/s)	7,500 ft/m (38 m/s)	6,500 ft/m (33 m/s)
<b>Allowable % BEP Range</b>	<b>20-120%</b>	<b>30-110%</b>	<b>40-100%</b>

All Wilfley S3 pumps also have a “Minimum Thermal Flow.” This is defined as the minimum flow that will not cause an excessive temperature rise. Minimum Thermal Flow is application dependent.

## WARNING

*Do not operate the pump at or below Minimum Thermal Flow, as this could cause an excessive temperature rise. Contact a Wilfley Sales Engineer for determination of Minimum Thermal Flow.*

## 4.4 Starting the Pump and Adjusting Flow

1. Open the suction valve to full open position. It is very important to leave the suction valve open while the pump is operating. Any throttling or adjusting of flow must be done through the discharge valve. Partially closing the suction valve can create serious NPSH and pump performance problems.

## DANGER

*Never operate pump with both the suction and discharge valves closed. This could cause an explosion.*

2. A standard centrifugal pump will not move liquid unless the pump is primed. A pump is said to be “primed” when the casing and the suction piping are completely filled with liquid. Open discharge valve a slight amount. This will allow any entrapped air to escape and will normally allow the pump to prime, if the suction source is above the pump. When a condition exists where the suction pressure may drop below the pump’s capability, it is advisable to add a low-pressure control device to shut the pump down when the pressure drops below a predetermined minimum.
3. All cooling, heating and flush lines must be started and regulated.
4. Start the driver (typically, the electric motor).
5. Slowly open the discharge valve until the desired flow is reached, keeping in mind the minimum flow restrictions listed above.

## DANGER

*It is important that the discharge valve be opened within a short interval after starting the driver. Failure to do this could cause a dangerous build up of heat and possibly an explosion.*

## 6. *Reduced Capacity*

Avoid running a centrifugal pump at drastically reduced capacities or with the discharge valve closed for extended periods of time. This can cause severe temperature rise and the liquid in the pump may reach its boiling point. If this occurs at a minimum, the seal may be damaged, as it will be exposed to vapor, will have no lubrication and may score or seize to the stationary parts. It is also possible that it can create an explosive condition. If the suction valve is also closed, there is an even greater risk of catastrophic failure such as an explosion.

Thermostats may be used to safeguard against overheating by shutting down the pump at a predetermined temperature

Safeguards should also be taken against possible operation with a closed discharge valve, such as installing a bypass back to the suction source. The size of the bypass line and the required bypass flow rate is a function of the input horsepower and the allowable temperature rise.

## 7. *Reduced Head*

Note that when discharge head drops, the pump's flow rate usually increases rapidly. Check motor for temperature rise as this may cause overload. If overloading occurs, throttle the discharge.

## 8. *Surging Condition*

A rapidly closing discharge valve can cause a damaging pressure surge. A dampening arrangement should be provided in the piping.

## 4.5 Thermal Shock Instructions

For thermal shock start-up instructions, please contact the Wilfley factory in Denver.

## 4.6 Operation in Sub-Freezing Conditions

When using the pump in sub-freezing conditions where the pump is periodically idle, the pump should be properly drained or protected with thermal insulating devices which will keep the liquid in the pump from freezing. High-chrome iron pumps are not recommended for applications below 0°F (-18°C).

## 4.7 Shutdown Considerations

When the pump is being shut down, the procedure should be the reverse of the start-up procedure. First, slowly close the discharge valve, shut down the driver and then close the suction valve. Remember, closing the suction valve while the pump is running is a safety hazard and could seriously damage the pump and other equipment.

## 5.0 Preventive Maintenance

### 5.1 General Servicing

Your Wilfley Model S3 pump is designed to provide long and trouble-free service with a minimum of maintenance. It is recommended that the pump be inspected at regular intervals. It is also suggested that a service record be kept for the pump.

### Motor

Refer to the motor manufacturer's manual for recommended service instructions. It is recommended that the motor be well ventilated when in operation.

### 5.2 Periodic Servicing

The following table contains recommended service checks that should be performed on a periodic basis.

	After First Start-Up	Every Week	Every 6 Months
Flow, Pressure, Temperature (a)	X	X	
Visual (b)	X	X	
Noise / Vibration	X	X	
Oil Level	X	X	
Grease Bearings	X		X

- a. **Flow, Pressure, Temperature:** All flow, pressure and temperature gauges should be monitored to ensure that the pump is operating within specified limits. If the frame temperatures are monitored, this temperature generally should not exceed 160°F (71.1°C).
- b. **Visual:** Periodic visual inspection should be made of the pump and its installation.

This inspection should include the following:

1. All mounting supports should be secure.
2. All external nuts, bolts and fittings should be tight.
3. All suction and discharge piping should be secure.
4. All surfaces and joints should show no signs of leakage.

## WARNING

To re-grease bearings under the coupling guard, stop pump, lock the motor, remove the coupling guard, then re-grease the bearings.

### Need for Maintenance Records

A procedure for keeping accurate maintenance records is a critical part of any program to improve pump reliability. There are many variables that can contribute to pump failures. Analyzing these variables through pump maintenance records can only solve often-long term and repetitive problems.

### Need for Cleanliness

One of the major causes of pump failure is the presence of contaminants in the bearing housing. This contamination can be in the form of moisture, dust, dirt and other solid particles, such as metal chips. Contamination can also be harmful to the seal (especially the seal faces) as well as other parts of the pumps. For example, dirt in the impeller threads could cause the impeller to not be seated properly against the shaft. This, in turn, could cause a series of other problems. For these reasons, it is very important that proper cleanliness be maintained.

### 5.3 Maintenance Troubleshooting

The following is a guide to troubleshooting problems with Wilfley pumps. Common problems are analyzed and solutions are offered.

Obviously, it is impossible to cover every possible scenario. If a problem exists that is not covered by one of the examples, then contact a Wilfley Sales Engineer or Wilfley Distributor/Representative for assistance.

See next page.

PROBLEM	POSSIBLE CAUSE	RECOMMENDED REMEDY
Pump not reaching design flow rate. Problem #1	Insufficient NPSH.	Recalculate NPSH available. It must be greater than the NPSH required by pump at desired flow. If not, redesign suction piping, holding the number of elbows and number of planes to a minimum to avoid adverse flow rotation as it approaches the impeller.
	System head greater than anticipated.	Reduce system head by increasing the pipe size and/or reducing the number of fittings.
	Entrained air. Air leak from atmosphere on suction side.	Check suction line gaskets and threads for tightness. If vortex formation is observed in the suction tank, install vortex breaker. Check for minimum submergence.
	Entrained gas from process.	Process-generated gases may require larger pumps.
	Speed too low.	Check motor speed against design speed.
	Direction of rotation wrong.	After confirming wrong rotation, reverse any two of three leads on a three-phase motor. The pump should be disassembled and inspected before it is restarted.
	Impeller too small.	Replace with proper diameter impeller. NOTE: Increasing impeller diameter may require use of a larger motor.
	Impeller clearance too large.	Reset impeller clearance.
	Plugged impeller, suction line or casing, which may be due to a product or large solids.	Reduce length of fiber when possible. Reduce solids in the process fluid when possible. Consider larger pump.
Wet-end parts (casing cover, impeller) worn, corroded or missing.	Replace part or parts.	
Pump not reaching design head (TDH). Problem #2	Refer to possible causes under Problem #1.	Refer to remedies listed for Problem #1 & #3.
No discharge or flow. Problem #3	Not properly primed.	Repeat priming operation and recheck instructions. If pump has run dry, disassemble and inspect the pump before operation.
	Direction of rotation wrong.	After confirming wrong rotation, reverse any two of three leads on a three-phase motor. The pump should be disassembled and inspected before operation.
	Entrained air. Air leak from atmosphere on suction side.	Check suction line gaskets and threads for tightness. If vortex formation is observed in suction tank, install vortex breaker. Check for minimum submergence.
	Plugged impeller and/or suction line casing, which may be due to a fibrous product or large solids.	Reduce length of fiber when possible. Reduce solids in the process fluid when possible. Consider larger pump.
	Damaged pump shaft and/or impeller.	Replace damaged parts.
Pump operates for short period, then loses prime. Problem #4	Insufficient NPSH.	Recalculate NPSH available. It must be greater than the NPSH required by pump at desired flow. If not, redesign suction piping, holding the number of elbows and number of planes to a minimum to avoid adverse flow rotation as it approaches the impeller.

PROBLEM	POSSIBLE CAUSE	RECOMMENDED REMEDY
	Entrained air. Air leak from atmosphere on suction side.	Check suction line gaskets and threads for tightness. If vortex formation is observed in the suction tank, install vortex breaker. Check for minimum submergence.
Excessive noise from wet end. Problem # 5	Cavitation – insufficient NPSH available.	Recalculate NPSH available. It must be greater than the NPSH required by pump at desired flow. If not, redesign suction piping, holding the number of elbows and number of planes to a minimum to avoid adverse flow rotation as it approaches the impeller.
	Abnormal fluid rotation due to complex suction piping.	Redesign suction piping, holding the number of elbows and number of planes to a minimum to avoid adverse fluid complex suction piping rotation as it approaches the impeller.
	Impeller rubbing.	Check and reset impeller clearance. Check outboard bearing assembly for axial endplay.
Excessive noise from power end. Problem #6	Bearing contamination appearing on the raceways as scoring, pitting, scratching or rusting caused by adverse environment and entrance of abrasive contaminants from atmosphere.	Replace bearings. Work with clean tools in clean surroundings. Remove all outside dirt from housing before exposing bearings. Handle with clean, dry hands. Treat a used bearing as carefully as a new one. Use clean solvent and flushing oil. Protect disassembled bearing from dirt and moisture. Keep bearings wrapped in paper or clean cloth while not in use. Clean inside of housing before replacing bearings. Check oil seals and replace as required. Check all plugs and tapped openings to make sure that they are tight.
	Brinelling of bearing identified by indentation on the ball races, usually caused by incorrectly applied forces in assembling the bearing or by shock loading such as hitting the bearing or drive shaft with a hammer.	Replace bearings. When mounting the bearing on the drive shaft use a proper size ring and apply the pressure against the inner ring only. Be sure, when mounting a bearing, to apply the mounting pressure slowly and evenly.
	False brinelling of bearing identified by either axial or circumferential indentations usually caused by vibration of the balls between the races in a stationary bearing.	Replace bearings. Where bearings are oil lubricated and employed in units that may be out of service for extended periods, the drive shaft should be turned over periodically to relubricate all bearing surfaces at intervals of one to three months. Correct the source of vibration.
	Thrust overload on bearing identified by flaking ball path on one side of the outer race or, in the case of maximum capacity bearings, may appear as a spalling of the races in the vicinity of the loading slot. These thrust failures are caused by improper mounting of the bearing or excessive thrust loads.	Replace bearings. Follow correct mounting procedures for bearings.

PROBLEM	POSSIBLE CAUSE	RECOMMENDED REMEDY
(Cont.) Excessive noise from power end. Problem #6	Misalignment identified by fracture of ball retainer or a wide ball path on the inner race and a narrower cocked ball path on the outer race. Misalignment is caused by poor mounting practices or defective drive shaft. For example, bearing not square with the centerline or possibly a bent shaft due to improper handling.	Replace bearings. Handle parts carefully and follow recommended mounting procedures. Check all parts for proper fit and alignment.
	Bearing damaged by electric arcing identified as electro-etching of both inner and outer ring or as pitting or cratering. Electrical arcing is caused by a static electrical charge emanating from belt drives, electrical leakage or short-circuiting.	Replace bearings. Where current shunting through the bearing cannot be corrected, a shunt in the form of a slip-ring assembly should be incorporated. Check all wiring, insulation and rotor windings to be sure that they are sound and all connections are properly made. Where pumps are belt driven, consider the elimination of static charges by proper grounding or consider belt material that is less generative.
	Bearing damage due to improper lubrication, identified by one or more of the following: Abnormal bearing temperature rise A stiff, cracked grease appearance. A brown or bluish discoloration of the bearing races.	Replace bearings. Be sure the lubricant is clean. Be sure proper amount of lubricant is used. In the case of greased, lubricated bearings, be sure that there is space adjacent to the bearing into which it can rid itself of excessive lubricant; otherwise, the bearing may overheat and fail prematurely. Be sure the proper grade of lubricant is used.

## 6.0 S3 Disassembly and Reassembly

The following sections of this manual give instructions on how to perform a complete maintenance overhaul. However, it is also important to periodically repeat the "Pre start-up checks" listed in section 4.2. These checks will help extend pump life as well as the length of time between major overhauls.

Note: The pictures in the following section represent typical parts to clarify assembly. Details of the parts may differ slightly from parts supplied with the pump.

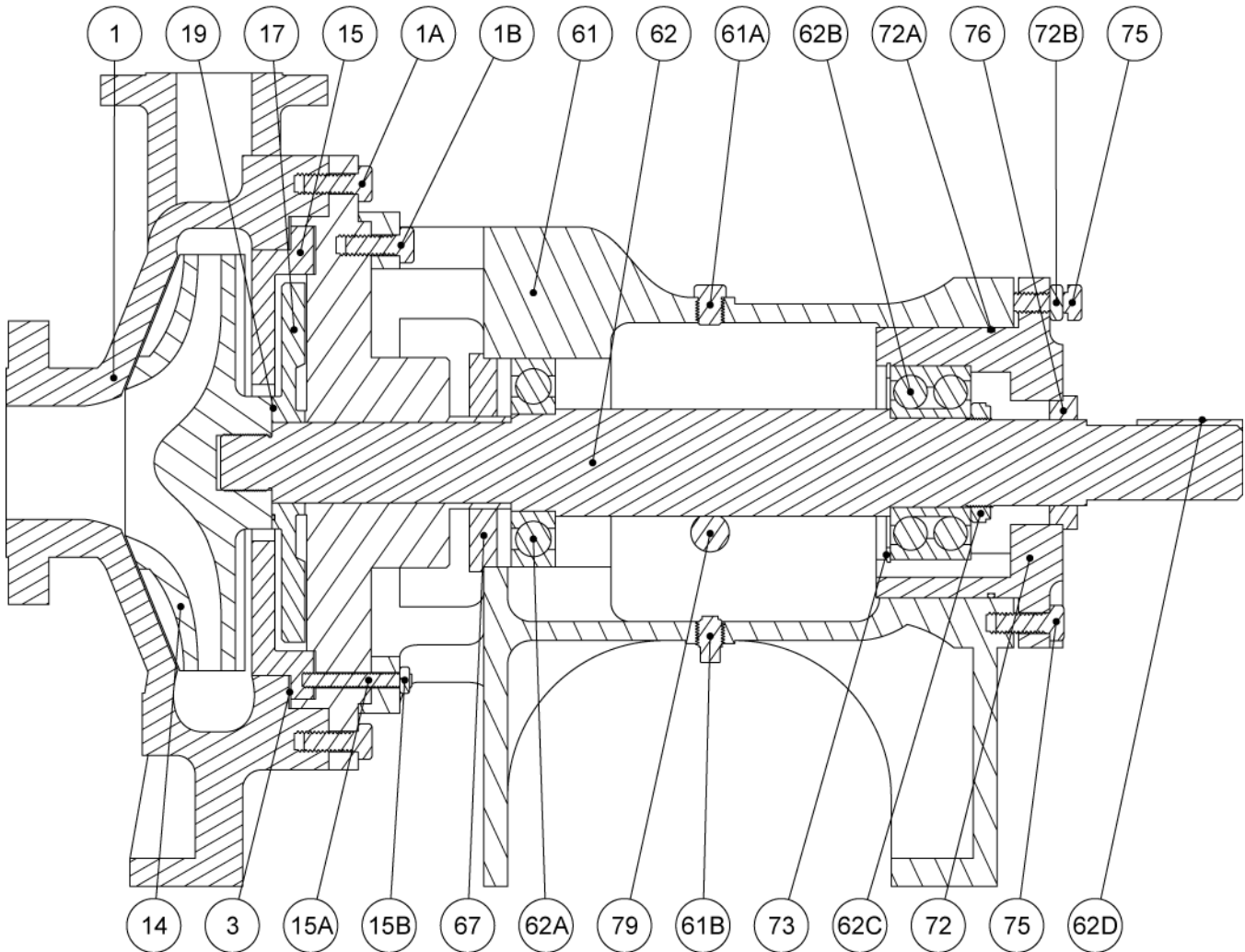

ITEM NO.	QTY.	DESCRIPTION
1	1	CASING
1A	8	CAP SCREW
1B	4	CAP SCREW
3	1	CASE GASKET
14	1	IMPELLER
15	1	CASE PLATE
15A	2	STUD
15B	2	JAM NUT
17	1	EXPELLER
19	1	O-RING, EXPELLER
61	1	BEARING FRAME
61A	1	OIL FILL PLUG
61B	1	OIL DRAIN PLUG

ITEM NO.	QTY.	DESCRIPTION
62	1	SHAFT
62A	1	INBOARD BEARING
62B	1	OUTBOARD BEARING
62C	1	LOCKNUT
62D	1	SHAFT KEY
67	1	INBOARD OIL SEAL
72	1	BEARING CARRIER
72A	1	O-RING, BEARING CARRIER
72B	3	JAM NUT
73	1	RETAINING RING
75	6	CAP SCREW
76	1	OUTBOARD OIL SEAL
79	2	OIL SIGHT GLASS



## 6.1 Disassembly

1. Before performing any maintenance, disconnect the driver from its power supply and lock it off line.

**DANGER**

*Lock out power to driver to prevent personal injury.*

2. Close the discharge and suction valves and drain all liquid from the pump.
3. Close all valves on auxiliary equipment and piping, then disconnect all piping.
4. Decontaminate the pump as necessary.

**DANGER**

*If Wilfley pumps contain dangerous chemicals, it is important to follow plant safety guidelines to avoid personal injury or death.*

5. Remove the coupling guard.
6. Remove the spacer from the coupling.
7. Disconnect any seal drain piping.
8. Remove the fasteners holding the bearing frame (61) and case (1) to the baseplate. Remove pump and relocate to a workstation.

**CAUTION**

*It is important to follow plant safety guidelines when lifting pump components.*

9. Remove drain plug (61B) and drain oil from the bearing frame (61). Replace drain plug when done.
10. Remove the coupling hub from the pump shaft (62).
11. Remove the fasteners (1A) holding the casing to the bearing frame, remove casing (1) and discard the casing gasket (3).

12. Mount a shaft key (62D) and a shaft wrench to the end of the shaft (62). With the wrench handle pointing to the left when viewed from the impeller end, grasp the impeller (14) firmly with both hands (wear heavy gloves) and then rotate it until the wrench handle is at the 11 o'clock position; next, spin the impeller (14) quickly in a counterclockwise direction so that the wrench end makes a sudden impact with a hard surface. After several sharp raps, the impeller (14) should be loose.

13. Unscrew the impeller (14) and remove it from the shaft (62).

**DANGER**

*Do not apply heat to the impeller (14). An explosion could occur.*

14. Remove the fasteners (15B) holding the case plate (15) to the bearing frame (61). Next, remove the case plate (15) and the expeller (17).
15. Remove the fasteners (1B) holding the seal assembly to the bearing frame (61). Next, remove the complete seal assembly.
16. Loosen the three jam nuts (72B) on the three jacking bolts (75) on the bearing carrier (72), then remove the three bolts (75). Loosen and remove the three retaining bolts (75).
17. Remove the bearing carrier assembly with the shaft (62) and bearings (62A & 62B) from the bearing frame (61) and discard the o-ring (73).
18. Remove the oil seals (67 & 76) from the bearing frame (61) and discard them.

Further disassembly is not required unless the bearings (62A & 62B) are to be replaced.

## Replacing the Bearings

1. Remove the retaining ring (73) from the groove of the bearing carrier (72).
2. The bearing locknut (62C) may now be removed from the shaft (62).

3. An arbor or hydraulic press may be used to remove the bearings (62A & 62B) from the shaft (62). It is extremely important to apply even pressure to the inner bearing race only. Never apply pressure to the outer race as this exerts excess load on the balls and causes damage. We recommend that all bearings be replaced after disassembly.

## CAUTION

*Applying pressure to the outer race could permanently damage the bearings.*

### 6.2 Cleaning/Inspection

All parts should now be thoroughly cleaned and inspected. New bearings, o-rings, gaskets and oil seals should be used. Any parts that show wear or corrosion should be replaced with OEM Wilfley parts.

#### Casing

- Thoroughly clean gasket surfaces and alignment fits to remove rust and debris.
- Inspect for any unusual erosive wear in volute.

#### Impeller/Expeller

- Inspect leading and trailing edges of vanes for pitting, erosion or corrosion damage.

#### Frame

- Inspect for cracks.
- Inspect for corrosion or pitting if there has been exposure to the pumpage.
- Inspect shaft (62) and sleeve for wear.
- Inspect bearing bores for roundness.

## WARNING

*It is important that only nonflammable, noncontaminated cleaning fluids are used. These fluids must comply with plant safety and environmental guidelines.*

### 6.3 Critical Measurement and Tolerances

To maximize reliability of pumps, it is important that certain parameters and dimensions are measured and maintained within specified tolerances. Any parts that do not conform to the specifications should be replaced with new Wilfley parts.

#### Shaft

The seal-mounting surface includes the shaft (62) and/or shaft sleeve outside diameter within the seal housing and extending beyond to accommodate outside seals. To provide for the possible use of a mechanical seal, the tolerance of that diameter shall not exceed nominal minus 0.002 in. (0.05 mm).

Shaft (62) runout shall be limited as follows:

1. Shaft rotated on centers: 0.001 in. (0.025mm) full indicator movement reading at any point.
2. Outside diameter of shaft (62) or removable sleeve when installed on pump: 0.002 in. (0.05mm) full indicator movement at the gland end of the seal housing.

## 6.4 Assembly

Full thread length engagement is required for all fasteners.  
Lightly lubricate all seal o-rings to prevent damage.

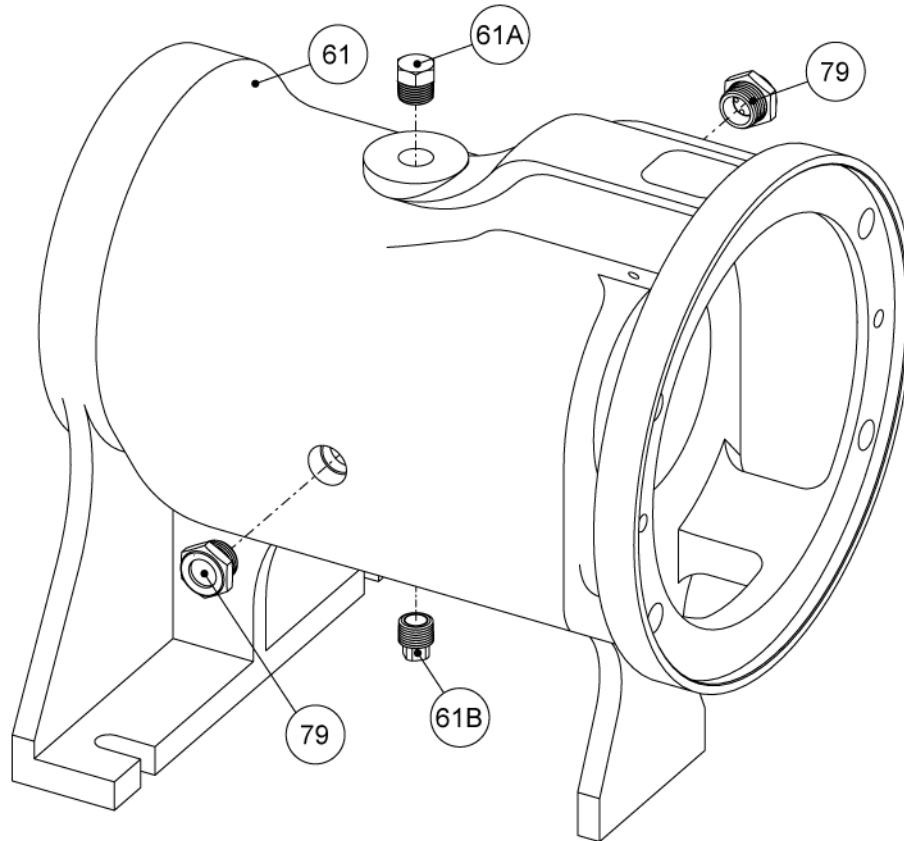

### Frame Assembly

1. Install oil fill plug (61A), oil drain plug (61B), and oil sight glasses (79) onto frame (61).

## Bearing Installation

Mounting of bearings (62A & 62B) on shaft (62) must be done in a clean environment. The service life of the power end can be drastically reduced if even very small foreign particles work their way into the bearings (62A & 62B).

Bearings (62A & 62B) should not be removed from their protective packaging until immediately before assembly to limit exposure to possible contamination. After the packaging is removed, bearings (62A & 62B) should only come into contact with clean hands, fixtures, tools and work surfaces.

Note that the term “inboard bearing” (62A) refers to the bearing nearest to the casing (1). “Outboard bearing” (62B) refers to the bearing nearest to the motor.

Both bearings (62A & 62B) have a slight and preferred interference fit that requires that they be pressed on the shaft (62) with an arbor or hydraulic press. Even force should be applied to the inner race only. Never press on the outer race, as the force will damage the balls and races. An alternate and preferred method of installing bearings (62A & 62B) is to heat them to 200°F (93°C) in an oven or with an induction heater. Then place them quickly in position on the shaft (62).

## CAUTION

*Never heat the bearings (62A & 62B) above 230°F (110°C). To do so will likely cause damage.*

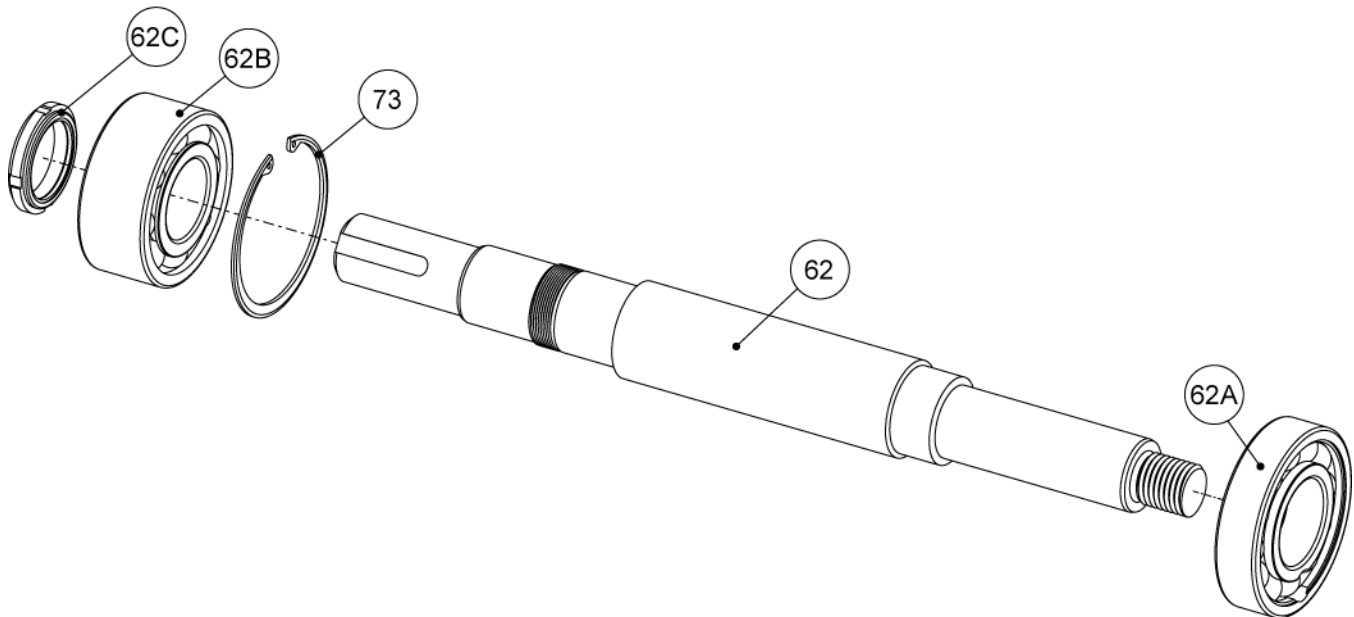

### Shaft Assembly Step 1

2. Install the retaining ring (73), outboard bearing (62B) and locknut (62C) onto the shaft (62). \*Note: Use back-to-back bearing orientation when there are two angular contact bearings.\* Then install inboard bearing (62A) onto shaft (62). It is recommended that a bearing heater be used when installing bearings to avoid damage to the races. Be sure the bearing (62A & 62B) seats against the shoulder of the shaft (62). If the pump is grease lubricated, hand pack the bearings (62A & 62B) with the appropriate grease (reference section 7.0) after they are seated on the shaft (62).

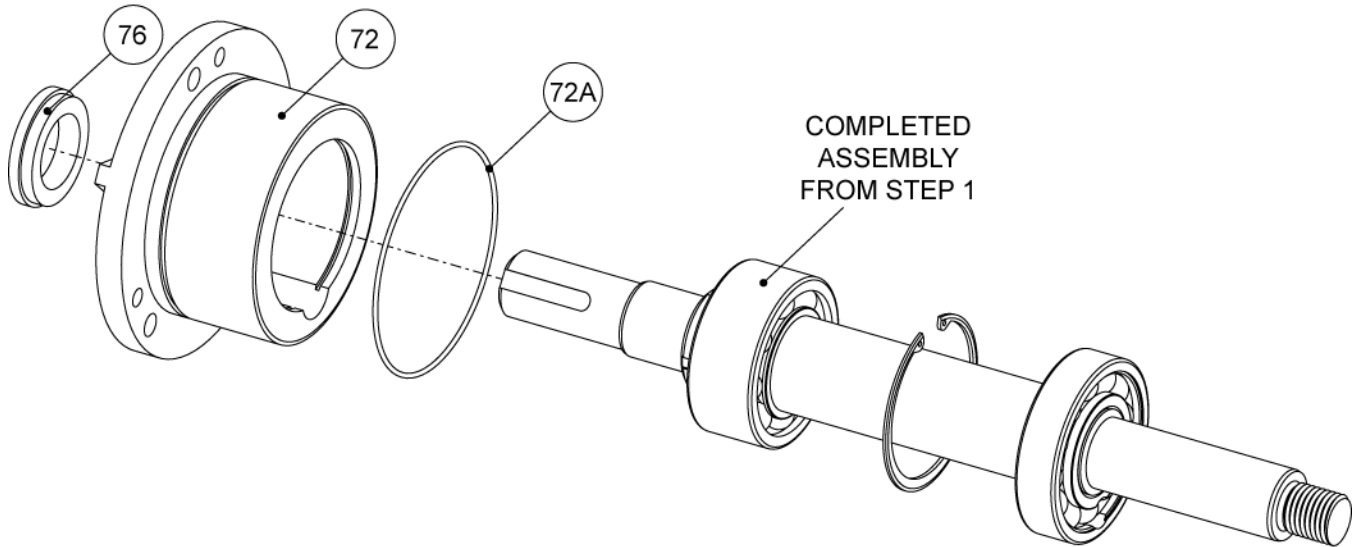

### Shaft Assembly Step 2

3. Install the outboard oil seal (76) into the bearing carrier (72). Please be sure that the notch in the seal faces down for drainage. Install o-ring (72A) onto bearing carrier (72). Slide bearing carrier (72) over outboard bearing (62B) and attach retaining ring (73). Be sure retaining ring (73) is fully seated in the groove.

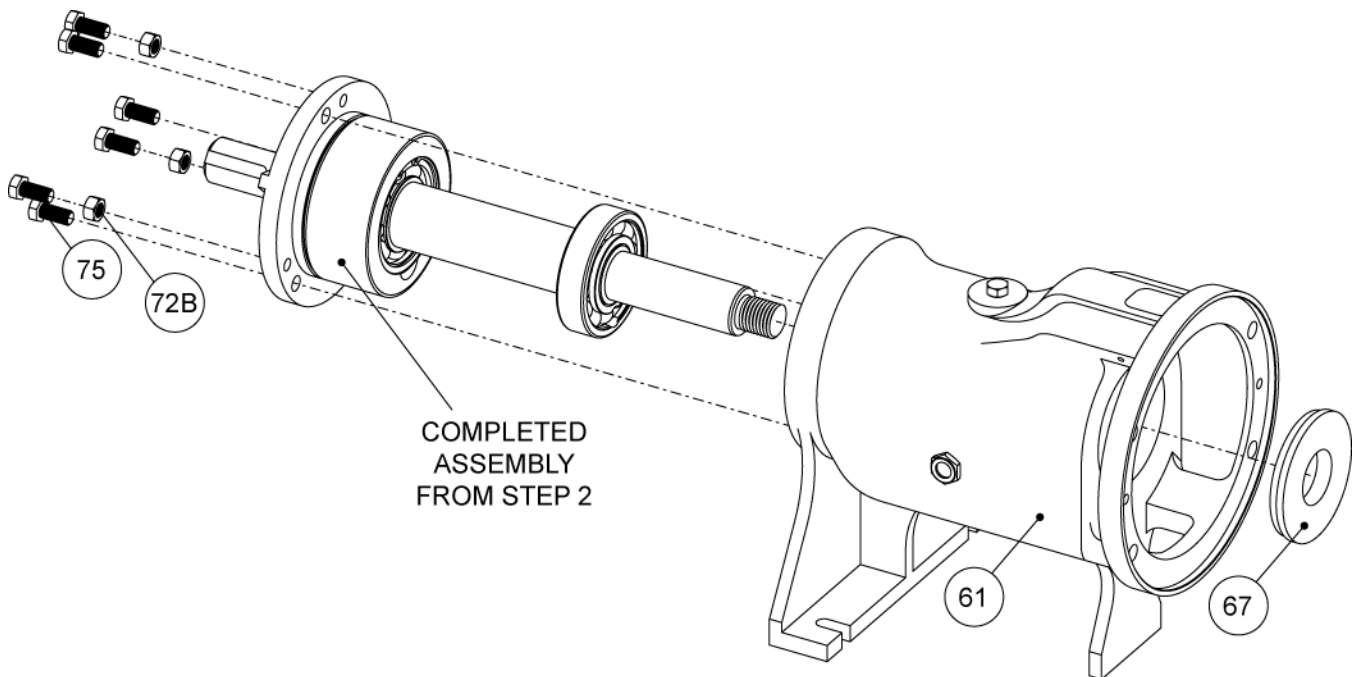

### Shaft Assembly Step 3

4. Install the inboard oil seal (67) into the frame (61). To avoid damage, lubricate the o-ring (72A) with light oil and slide the assembly into the frame (61). The word "top" on the carrier (72) must face up. Attach the bearing carrier (72) with three retaining bolts (75), jacking bolts (75) and jam nuts (72B).

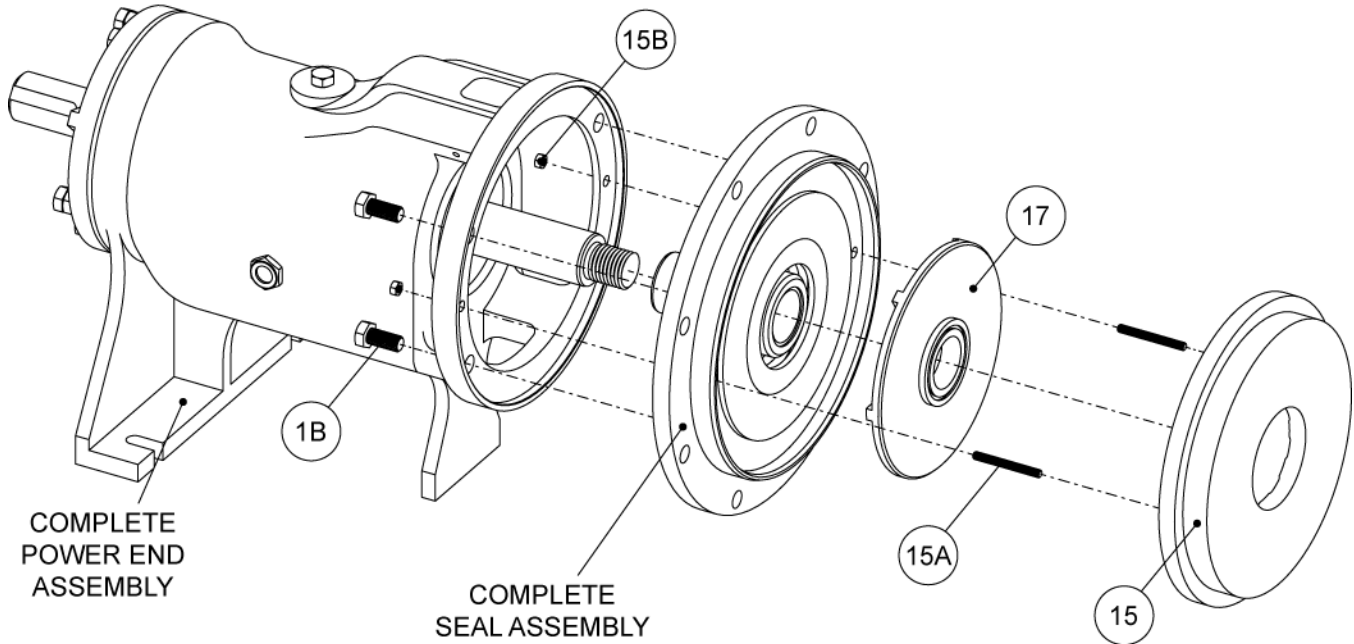

## Complete Pump Assembly Step 1

5. Assemble the seal assembly according to the supplemental assembly manual.
6. Install the seal assembly on the power end with bolts (1B). The seal flush should be at the 12 o'clock position and the drain at the 6 o'clock position. A drain nipple may have been supplied with the seal assembly. The nipple can be screwed in to the drain port after pump assembly, use Teflon tape on the threads.
7. Place the expeller (17) onto the shaft (62).
8. Place the case plate (15) onto the seal assembly and secure in place with studs (15A) and nuts (15B).

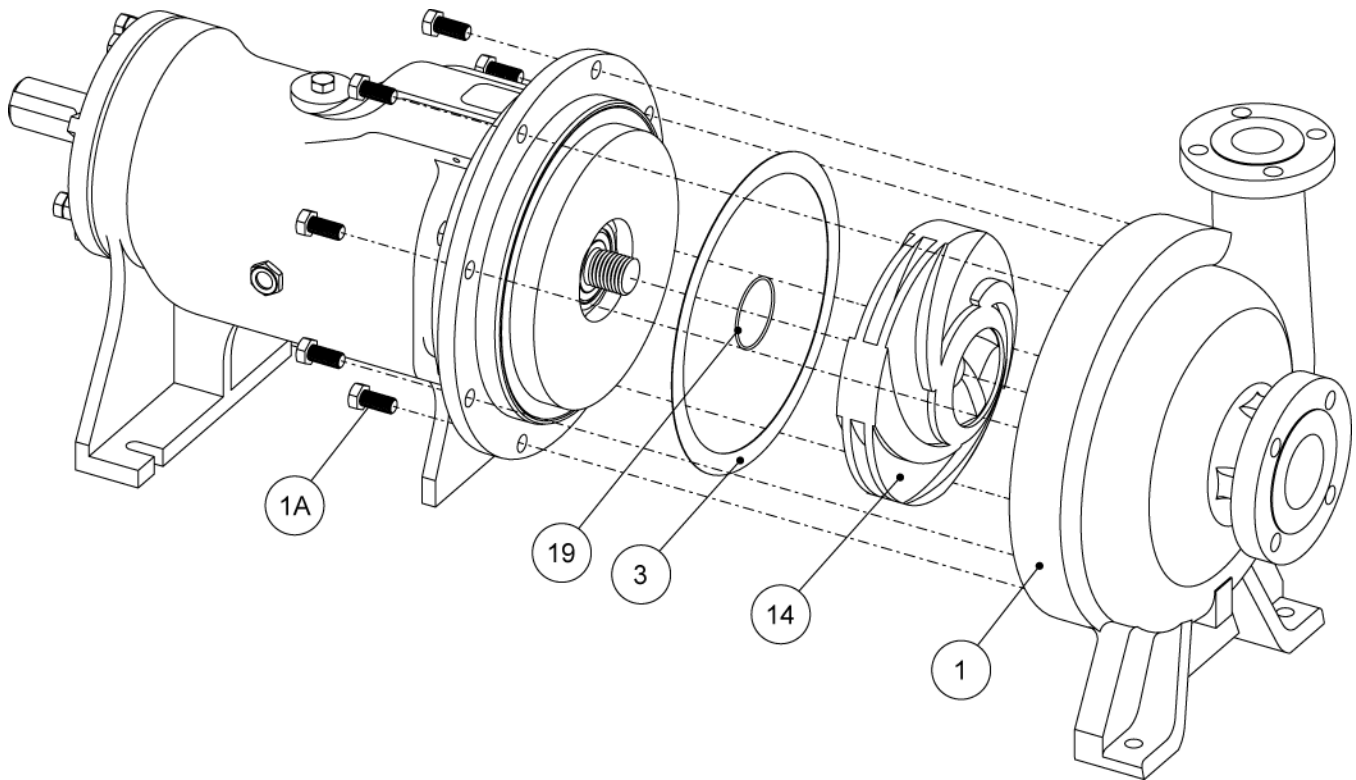

## Complete Pump Assembly Step 2

9. Place the impeller o-ring (19) into the groove on the expeller (17).
10. Screw the impeller (14) onto the shaft (62). Be sure the impeller (14) is securely tightened; use of a shaft wrench is recommended to assist in the tightening process.
11. Install case gasket (3) onto the seal assembly. Use a grease type substance to secure the gasket (3) if it does not stay in place.
12. Secure the casing (1) to the power end with the supplied bolts (1A).
13. Set the impeller clearances using one of the following methods. Wilfley recommends that the dial indicator method be used to set the clearances.
14. Set the seal clearances using the supplemental assembly manual.

## 6.5 Setting Impeller Clearance

### Dial Indicator Procedures

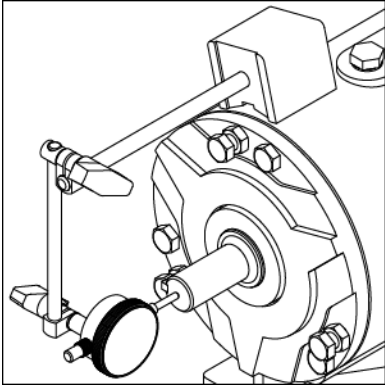

#### Dial Indicator Method (Preferred Method)

1. Loosen cap screws (75) and the nuts (72B) on the jacking screws (75). Tighten the jacking screws (75) to pull the bearing carrier (72) out from the frame (61) until the shaft (62) will not turn due to metal-to-metal contact in the pump.
2. Set the dial indicator so that the button contacts the end of the shaft. Set indicator at a minimum of 0.040 in (1.016 mm).
3. Draw the bearing unit into the frame (61) with the cap screws (75) a total of 0.020 in (0.508 mm).
4. Evenly tighten all jack and retaining bolts (75) so that they are equally tight. Recheck the dial indicator to ensure the proper clearance has been maintained.
5. Check shaft (62) to be sure it turns freely.

### Feeler Gauge Procedures

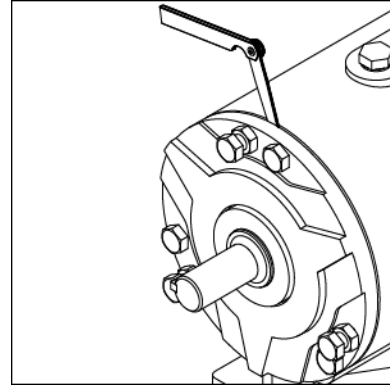

#### Feeler Gauge Method

1. Loosen cap screws (75) and the nuts (72B) on the jacking screws (75). Tighten the jacking screws (75) to pull the bearing carrier (72) out from the frame (61) until the shaft (62) will not turn due to metal-to-metal contact in the pump.
2. Measure the total clearance between the bearing unit and the frame (61). Draw the bearing unit into the frame (61) with the cap screws (75) until the gap is 0.020 in (0.508 mm) less than the original measurement.
3. Evenly tighten all jack and retaining bolts (75) so that they are equally tight. Recheck the dial indicator to ensure the proper clearance has been maintained.
4. Check shaft (62) to be sure it turns freely.



## 6.6 Assembly Troubleshooting

See table below for possible assembly issues.

SYMPTOM	CAUSE
Excessive shaft endplay.	Bearing internal clearance too great. Replace bearings with correct type. Snap ring loose in bearing housing groove. Reseat.
Excessive shaft/sleeve runout.	Sleeve worn. Replace. Shaft bent. Replace.
Excessive bearing frame flange runout.	Shaft bent. Replace. Bearing frame flange distorted. Replace.
Excessive frame adapter runout.	Corrosion. Replace. Adapter to frame gasket not seated properly. Reseat.
Excessive seal housing box cover runout.	Seal housing not properly seated in frame. Corrosion or wear. Replace.
Excessive impeller vane tip runout.	Bent vane(s). Replace impeller.

## Reinstallation

1. Reinstall the pump to the base.

### CAUTION

*The pump should be reinstalled as described in the installation section by following the field installation and alignment procedures.*

2. Install the coupling following the manufacturer's installation instructions.
3. Install the coupling guard, ensuring that the guard is not in contact with the shaft and coupling.

Please refer to the pre start-up instructions. Follow all safety precautions and ensure that all safety guards are in place.

See next page.

## 6.7 Troubleshooting Pump Leaks

### Pump Leaks

Before removing your Wilfley pump, determine when the leakage is occurring: while running, or while not running. During these inspections you should try to determine the exact origin of the leak. Special attention should be given to the shaft sleeve. Once you have determined when the pump is leaking, refer to the guide below.

#### Pump Leaks While Running

Test	Test Results	Indicates
Visually determine the exact leakage point.	Leakage from the seal area at shaft sleeve.	Pump suction pressure exceeds expeller capacity.
		Excessive expeller wear, corrosion, clearance, or plating between vanes.
		Pump running too slowly.
	Leakage comes from case or gasket area.	Damaged seal surface, gasket failure or loose bolts.

#### Pump Leaks While NOT Running

Test	Test Results	Indicates
Verify that leakage originates from the seal area.	Leakage comes from case or gasket area.	Damaged sealing surface gasket failure or loose bolts.
Verify that leakage originates from the seal area.	Leakage is observed on seal or shaft sleeve.	Seal or actuator problem.

## 7.0 Lubrication

### Bearing Lubrication

#### Oil Lubrication

Fill the frame until the oil level is approximately in the middle of the sight glass.

#### Acceptable Oils

<b>Chevron</b>	GTS Oil 68
<b>Exxon</b>	Teresstic EP 68
<b>Gulf</b>	Gulf Harmony 68
<b>Mobil</b>	Mobil DTE26 300 SSU 100°F (38°C)
<b>Phillips</b>	Mangus Oil Grade 315
<b>Phillips</b>	MM motor Oil SAE 20-20W

#### Lubricating Oil Requirements

	Process Liquid Temp. < 300°F (150°C)	Process Liquid Temp. > 300°F (150°C)
<b>ISO Grade</b>	VG 68	VG 100
<b>Approx. SSU at 100°F (38°C)</b>	300	470
<b>DIN 51517</b>	C68	C100
<b>Kinem. viscosity at 105°F (40.6°C) in mm<sup>2</sup>/sec</b>	68	100

Wilfley recommends that the oil be changed according to the customer's preventive maintenance program. Every service can be different, which varies the length of time between oil changes. If a maintenance program is already in place, follow that. If no program is in place, Wilfley recommends changing the pump oil once every 3 months.

#### *Grease Lubrication*

Bearings should be hand packed during assembly and reassembly. Further lubrication should be done per periodic servicing (see section 5.2). Recommended grease: Grease SRI #2

## 8.0 Ordering Parts

Please include the serial number of your pump when ordering spare parts. With this number we can determine and duplicate the original configuration and materials of construction.

## 9.0 Special Service

The seal assembly is extremely important to the total, efficient operation of Wilfley S3 pumps. Its parts, gaskets and seals must be in good working order. Many times parts are replaced unnecessarily due to unfamiliarity with the assembly. The reverse is also true: parts that should be replaced are, at times, left in the assembly. For these reasons, we provide the service of rebuilding this assembly in our factory.

Your Wilfley S3 pumps and seals may be returned to the factory, at any time, for complete overhaul and repair. Each pump is completely disassembled and worn or inoperable parts are replaced. All rebuilt pumps are subjected to the same testing procedures as newly constructed units. We charge the standard price for parts and a minimal reassembly fee.

The utilization of this service provides you with almost instantaneous pump repair at an economical price. The units are overhauled and returned to you quickly.

Please contact A.R. Wilfley and Sons, Inc. or any of our authorized representatives at any time concerning our pumps or parts. You can be assured that we will do all within our power to ensure your complete satisfaction with Wilfley products.

A.R Wilfley and Sons, Inc.  
5870 E. 56<sup>th</sup> Avenue  
Commerce City, CO 80022  
USA

+1 (303) 779-1777  
+1 (800) 525-9930  
[www.wilfley.com](http://www.wilfley.com)

## 10.0 Revision History

Revision	Description	Date
B	<ul style="list-style-type: none"><li>Seal section removed. Seal assembly information can now be found in supplemental assembly manuals.</li></ul>	Apr. 2017