

Solidlock[®] Static Seal

Seal Cartridge

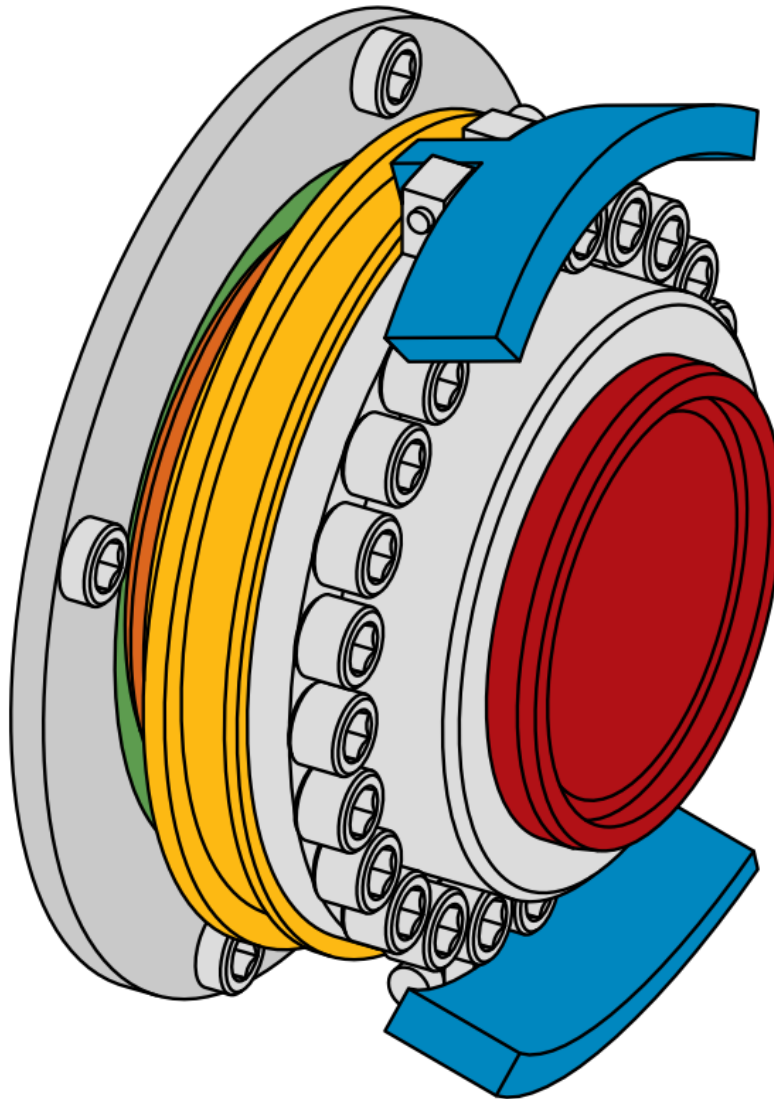

Supplemental Assembly Manual - IM-SL

www.WILFLEY.com

Table of Contents

FOREWORD	3
1.0 SEAL DESCRIPTION	4
1.1 STANDARD CONFIGURATION	5
1.2 PURGE PORT CONFIGURATION	6
2.0 PRE-INSTALLATION.....	7
3.0 SETTING THE SEAL – SOLIDLOCK.....	8
4.0 SPRING NUMBER	9
4.1 SPRING SPACING.....	9
4.2 ADJUSTING PERFORMANCE.....	10
5.0 ROTARY SEAL SUBASSEMBLY	11
5.1 ROTARY SEAL ASSEMBLY STEP 2.....	12
6.1 STATIONARY SEAL – A7/A9 CHEMICAL PUMP.....	13
6.2 STATIONARY SEAL - AF CHEMICAL PUMP	14
6.3 STATIONARY SEAL - EMW® SLURRY PUMP	15
6.4 STATIONARY SEAL - HD SLURRY PUMP	17
6.5 STATIONARY SEAL - KPRO® SLURRY PUMP	18
6.6 STATIONARY SEAL - S3 CHEMICAL SLURRY PUMP.....	20
7.0 RECOMMENDED SPARES.....	22
8.0 REVISION HISTORY	23

Foreword

This manual contains instructions and guidelines for the assembly of the Wilfley SolidLock® static seal cartridge. The information contained herein is meant to serve only as a general guideline. If detailed questions or problems arise, contact Wilfley or your authorized Wilfley representative.

Use of the equipment on a service other than what was specified at the time of purchase could void the warranty unless Wilfley has provided written approval otherwise.

To assure proper installation, supervision from an authorized Wilfley representative is recommended.

A.R. Wilfley and Sons, Inc. shall not be liable for damage or delays caused by a failure to observe the instructions that are contained in this manual.

Warranty is only valid when genuine Wilfley parts are used. Contact your authorized Wilfley representative for basic warranty information and before making any changes.

Proper pump selection should be made for applications based on conditions of service, material compatibility, solids content, fluid temperature, footprint size, as well as motor speed and energy considerations. Improper selection or improper use of pumps could risk injury or damage. For maximum safety and reliability, use only factory-supplied parts and closely follow all operating instructions and maintenance recommendations.

1.0 Seal Description

Wilfley Centrifugal pumps have a shaft seal designed for performance and dry running in a broad variety of applications called the Solidlock® static Seal. For pumping applications with abrasives and some degree of solids or particulates that tend to crystalize, the Solidlock seal is an excellent solution. The two seal faces operate as a dynamic seal in tandem with the pump's expeller.

Seal Name	Seal Type	Runs Dry	Solids	Crystallizing liquids	Vapors	High Temp.
Solidlock® Seal	Dynamic (with Expeller)	Yes	Yes	Yes	No	No

Upon start up, centrifugal forces act upon governor weights to physically separate the seal faces during rotation. This means there is no seal drag during operation, no wear or rubbing of parts or seal faces. At shut down, isolated springs force the seal faces to close prior to the transition of dynamic sealing to static sealing. The soft stationary seal face will flex outwards against the harder rotary seal face to eliminate leakage of internal pressure.

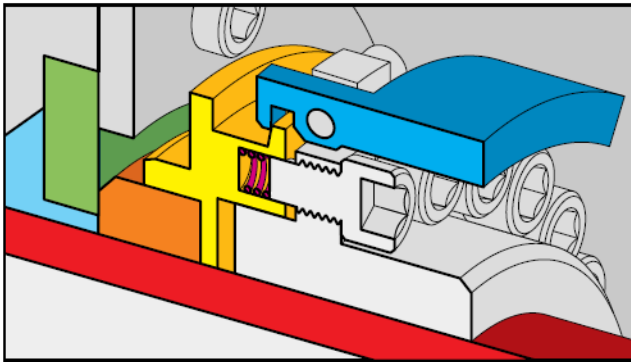

PUMP OFF / SEAL CLOSED

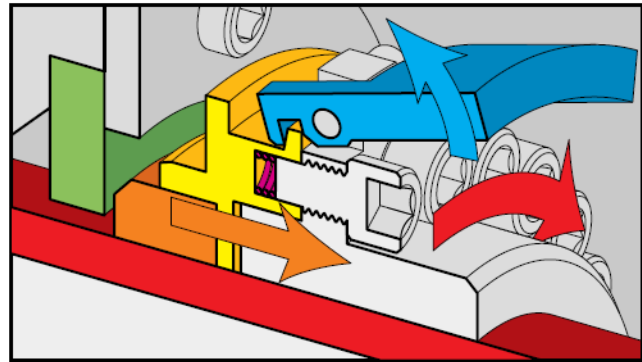

PUMP RUNNING / SEAL OPEN

The major components of the seal are the rotary seal assembly and the stationary seal. As indicated by their names, the stationary seal stays fixed in position, and the rotary seal rotates with the shaft of the pump.

The basis of performance is the static seal face which is designed to pull inward via the suction created by the expeller. This seal is optimum for slurry applications which will still seal with particles between the sealing faces because of the combination of seal faces.

A matched set of springs and governor weights are used in combination to open and close the seal at specifically designed speeds based on the customer's application.

No flushing plan is required and the Solidlock® seal may operate dry without issue, such as if a tank level is dropped accidentally. The cartridge design allows the units to be installed easily and quickly, offering installation in many Wilfley pump families.

The life of the seal is dependent upon the correct placement of the seal based on suction pressure, pump speed and characteristics of the pumping liquid. With the correct selection of materials, the unit will be able to accommodate up to 400 degrees Fahrenheit applications.

Since chemical processes are all unique, the construction material for the Solidlock® components should be reviewed for compatibility with the pumped liquid.

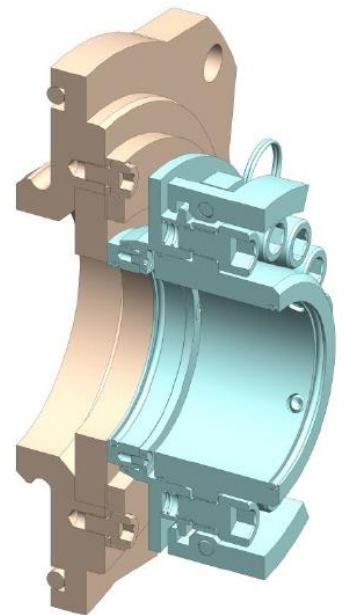

1.1 Standard Configuration

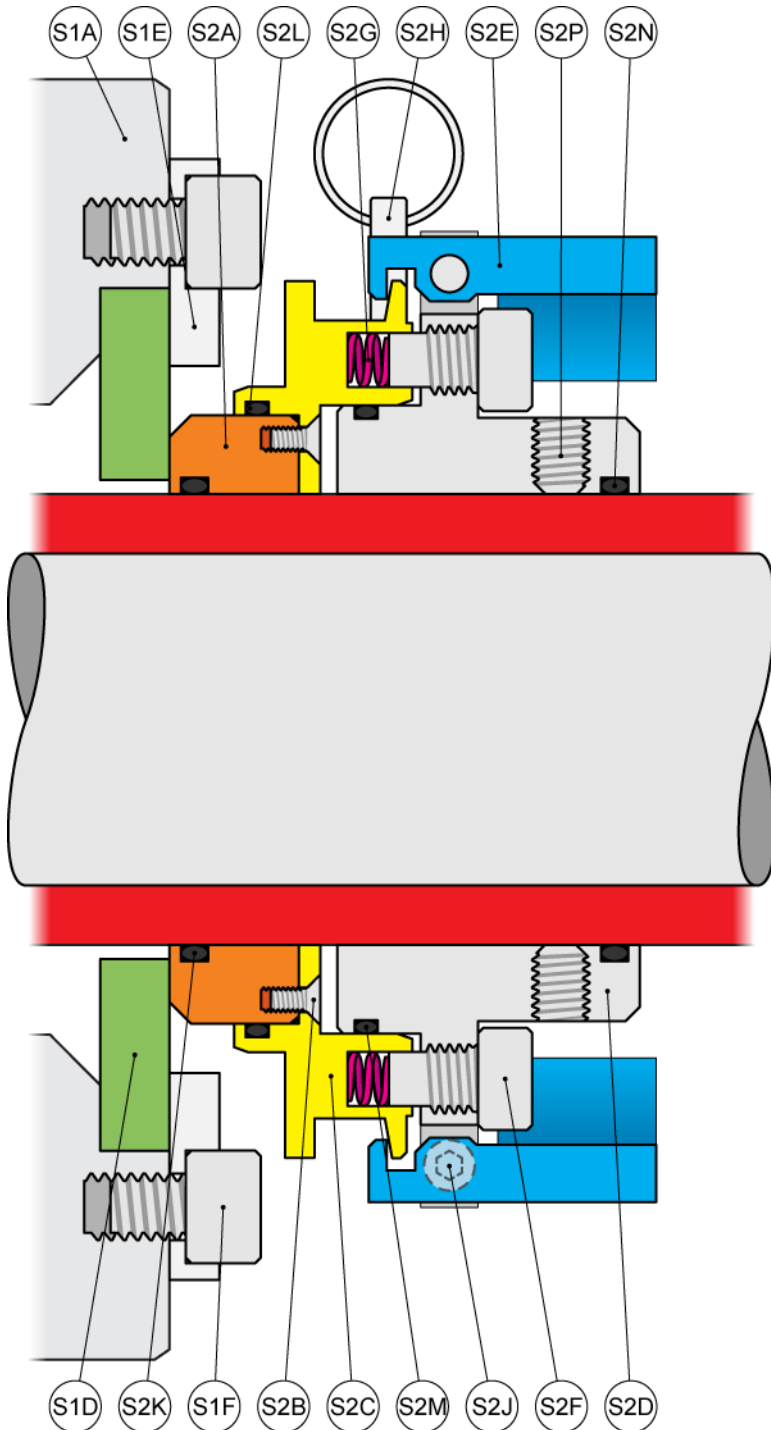

Ref. #	Description	Qty.
S1A	Stationary Seal Housing	1
S1D	Stationary Seal	1
S1E	Seal Lock	1
S1F	Stationary Seal Bolt	3-8
S2A	Rotary Seal	1
S2B	Rotary Seal Bolt	4
S2C	Rotary Seal Carrier	1
S2D	Weight Spider	1
S2E	Weight	2
S2F	Spring Bolt	TBD ¹
S2G	Spring	TBD ¹
S2H	Pull Pin	2
S2J	Weight Bolt	2
S2K	O-Ring, Rotary Seal	1
S2L	O-Ring, Rotary Seal Carrier	1
S2M	O-Ring, Weight Spider	1
S2N	O-Ring, Weight Spider to Shaft Sleeve	1
S2P	Shaft Sleeve Set Screw	4
See Table	Shaft Sleeve	1

1. Quantity varies with pump size and operating speed.

Not all components are used on each pump model.

Shaft Sleeve Ref. Numbers:

Model	Ref. #
A7	39
A9	5A
AF	14
EMW [®]	14
HD	17
Kpro [®]	19C
S3	39

1.2 Purge Port Configuration

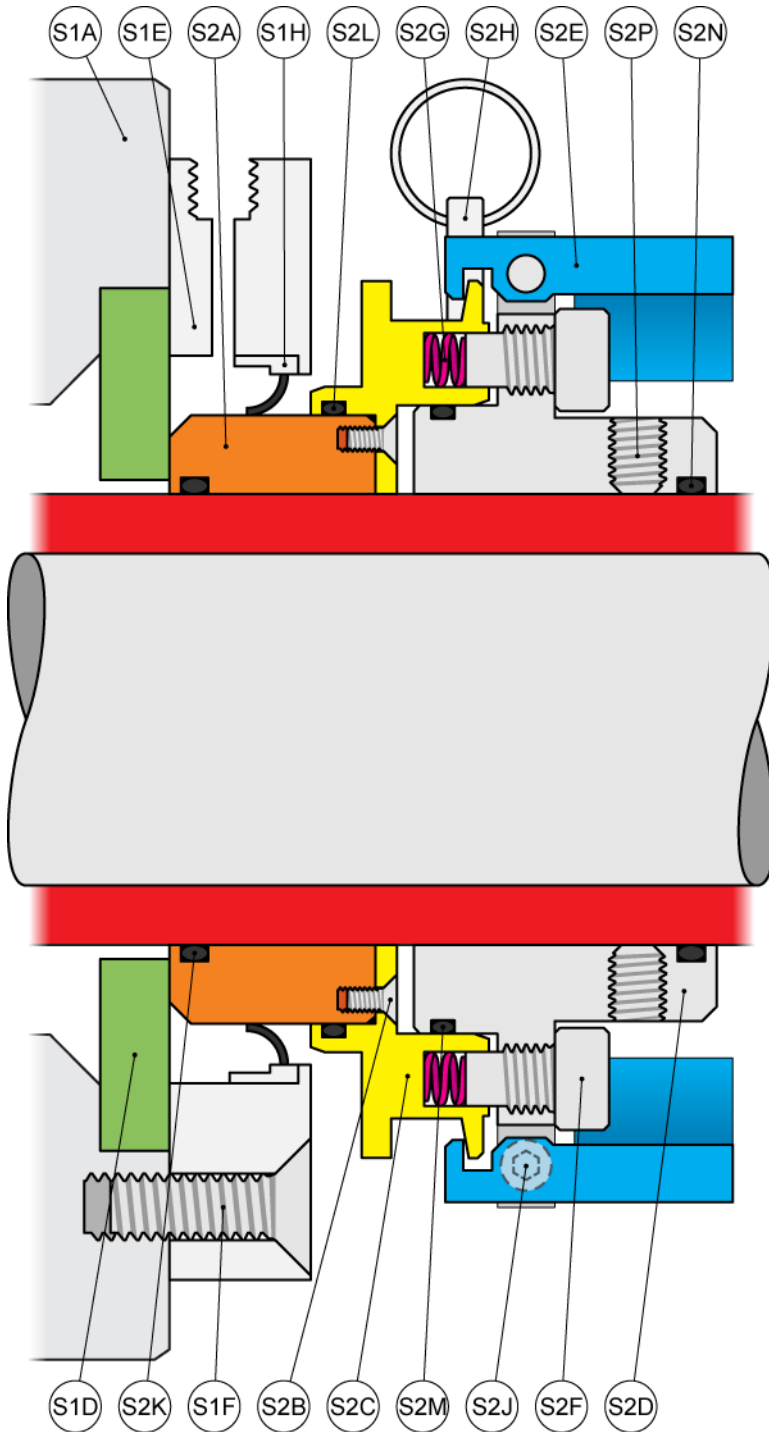

Ref. #	Description	Qty.
S1A	Stationary Seal Housing	1
S1D	Stationary Seal	1
S1E	Seal Lock	1
S1F	Stationary Seal Bolt	3-8
S1H	Lip Seal	1
S2A	Rotary Seal	1
S2B	Rotary Seal Bolt	4
S2C	Rotary Seal Carrier	1
S2D	Weight Spider	1
S2E	Weight	2
S2F	Spring Bolt	TBD ¹
S2G	Spring	TBD ¹
S2H	Pull Pin	2
S2J	Weight Bolt	2
S2K	O-Ring, Rotary Seal	1
S2L	O-Ring, Rotary Seal Carrier	1
S2M	O-Ring, Weight Spider	1
S2N	O-Ring, Weight Spider to Shaft Sleeve	1
S2P	Shaft Sleeve Set Screw	4
See Table	Shaft Sleeve	1

1. Quantity varies with pump size and operating speed.

Not all components are used on each pump model.

Shaft Sleeve Ref. Numbers:

Model	Ref. #
A7	39
A9	5A
AF	14
EMW [®]	14
HD	17
Kpro [®]	19C
S3	39

Back up and sealing of vapors is possible on select product lines.

2.0 Pre-Installation

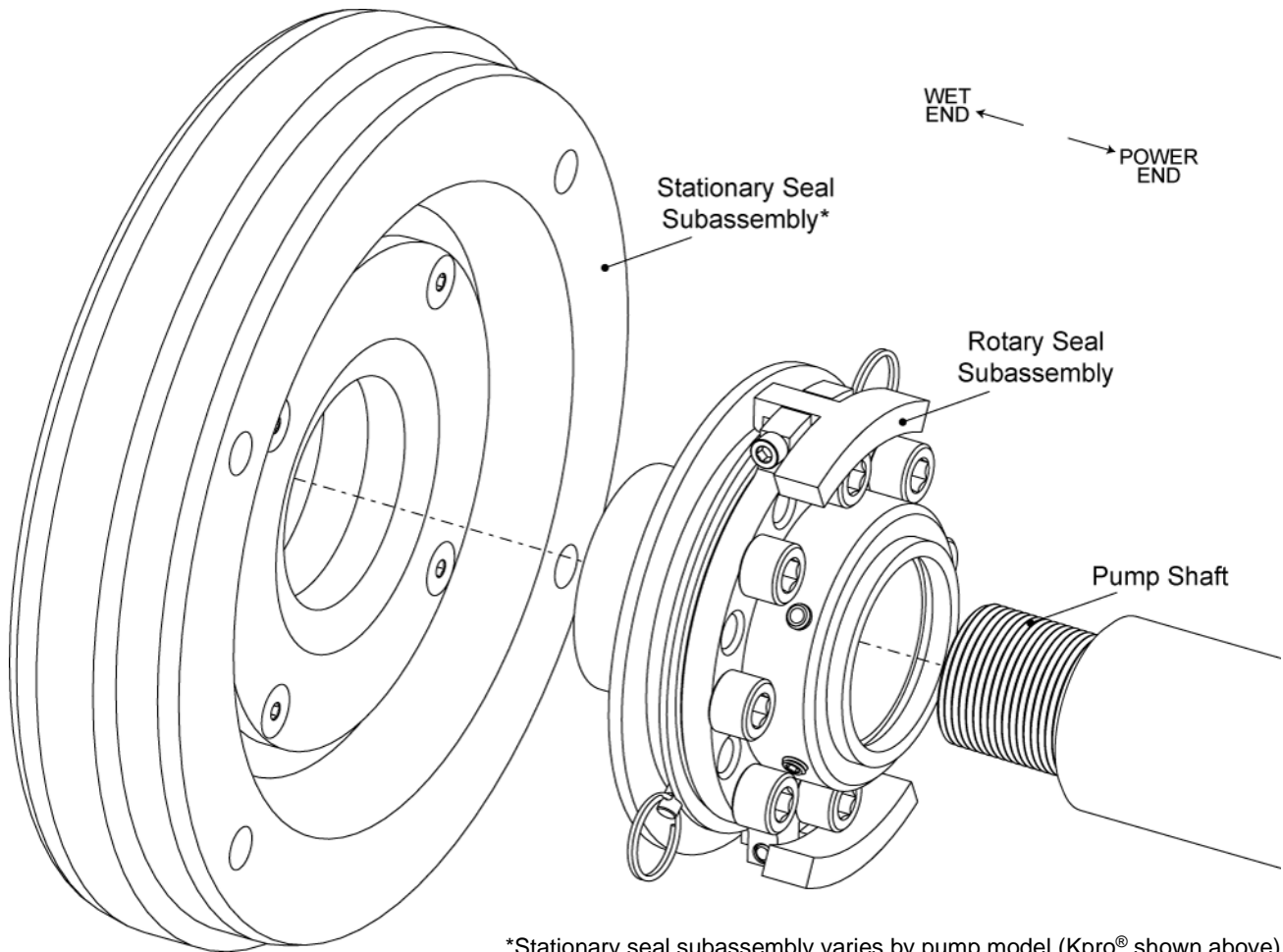

*Stationary seal subassembly varies by pump model (Kpro® shown above)

1. Assemble pump according to the pump IOM manual until the step to install the seal is reached.
2. Slide the rotary seal subassembly onto the pump shaft so that the weights and bolts face the bearing frame. Do not tighten the four set screws (S2P) on the subassembly yet.
3. Install stationary seal subassembly onto the pump so that the stationary seal (S1D) is facing the recently installed rotary seal assembly.
4. Complete final assembly of the pump according to the pump IOM manual – this will include setting the impeller clearances and final position of the shaft.
5. Set seal according to section **3.0 Setting the Seal**.

3.0 Setting the Seal – Solidlock

The seal MUST be adjusted and locked AFTER the pump has been assembled AND the impeller clearance has been set according to pump IOM. Before you begin, ensure that the set screws (S2P) are loose and that the rotary seal subassembly can freely move axially along the shaft sleeve.

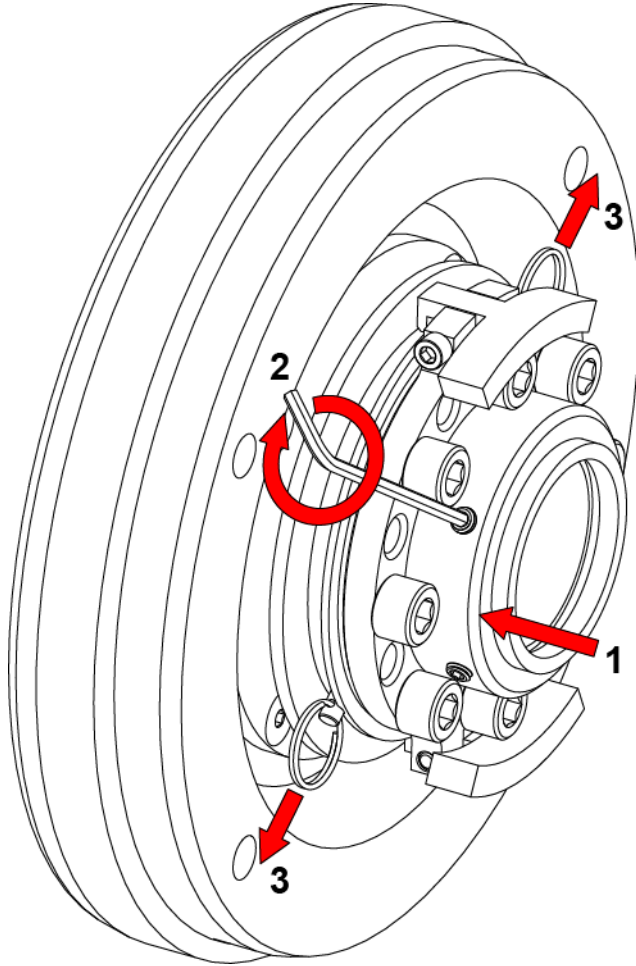

1. Firmly push the rotary seal subassembly against the stationary subassembly until the seal faces come into contact.

2. Evenly tighten the four set screws (S2P) to lock the position of the rotary seal subassembly to the shaft.

3. Pull the two pins (S2H) out of the rotary seal subassembly. It may be necessary to pull on the weights (S2E) or push the assembly slightly to be able to pull out the two pins (S2H).

The seal should be ready for use. One way to verify this is to check that the shaft has become more difficult to turn since the seal faces are engaged with each other.

When resetting pump clearances, performing maintenance, or disassembling the pump, the rotary seal subassembly must be reset by reinstalling the pull pins (S2H). Pulling up on the weight (S2E) nearest the hole with the pin (S2H) will help line up the two radial holes. Once both pins (S2H) are in, the set screws (S2P) may be loosened and the rotary seal subassembly may be adjusted or disassembled from the pump.

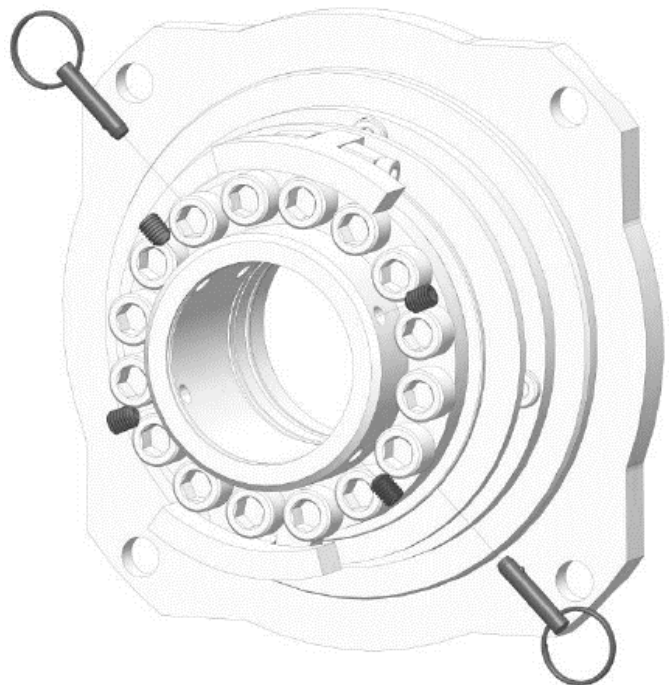

4.0 Spring Number

The Solidlock spring number depends on the weights used and the pump model. There are three weight sizes possible. Use the table to determine the quantity of springs required for your application. If you are using a variable frequency drive and are operating the pump as various speeds, use your lowest operating speed to determine the quantity of springs.

1A7 – 2A7 1A9 – 2A9 1AF – 4AF EMW50 – EMW75 1Kpro – 3Kpro		3A7 – 4A7 3A9 EMW100 4Kpro – 5Kpro		4A9 – 5A9 EMW150 6Kpro 1S3		EMW200 – EMW250 HD8x4 – HD8x6 8Kpro 2S3	
Small Weight		Medium Weight		Medium Weight		Large Weight	
Speed	Spring Qty.	Speed	Spring Qty.	Speed	Spring Qty.	Speed	Spring Qty.
< 1,400	4	< 600	6	< 600	4	< 400	4
1,400-1,600	6	600-800	8	600-700	8	400-500	6
1,600-1,800	8	800-900	10	700-800	12	500-600	8
1,800-2,000	10	900-1,000	12	800-900	14	600-700	10
> 2,000	12	1,000-1,100	14	900-1,100	16	700-800	12
		1,100-1,200	16	Small Weight		800-900	16
		Small Weight		Speed	Spring Qty.	900-1,000	20
		Speed	Spring Qty.	1,100-1,300	8	1,000-1,100	24
		1,200-1,400	6	1,300-1,500	10	Medium Weight	
		1,400-1,700	8	1,500-1,700	12	Speed	Spring Qty.
		1,700-2,000	10	1,700-1,900	14	> 1,100	24
		2,000-2,200	12	> 1,900	16		
		2,200-2,400	14				
		> 2,400	16				

SolidLock assemblies are shipped with the correct quantity of springs and weight size for your application. Identification of springs and weights may be found on the etched part number or the overall width from end to end. Alternatively, the part number may be found on the Pump Card or Bill of Materials listing. For clarification, Wilfley will be able to identify the size and number if the pump serial number is identified.

WEIGHT SIZE	Part #	Length
Small	A3193	2.6"
Medium	A3199-02	3.2"
Large	A3199	4.3"

4.1 Spring Spacing

Spring selection must be completed before assembly. During assembly, it is important for proper seal performance and actuation that the seal springs (S2G) be spaced evenly throughout the bolt pattern. As shown, this size seal assembly uses four springs. They are evenly spaced between the sixteen spring bolts (S2F).

It is also important that they be tightened in a criss-cross or star pattern to prevent any misalignment or cocked seal faces. As a visual indicator, all bolts should be bottomed to the same height.

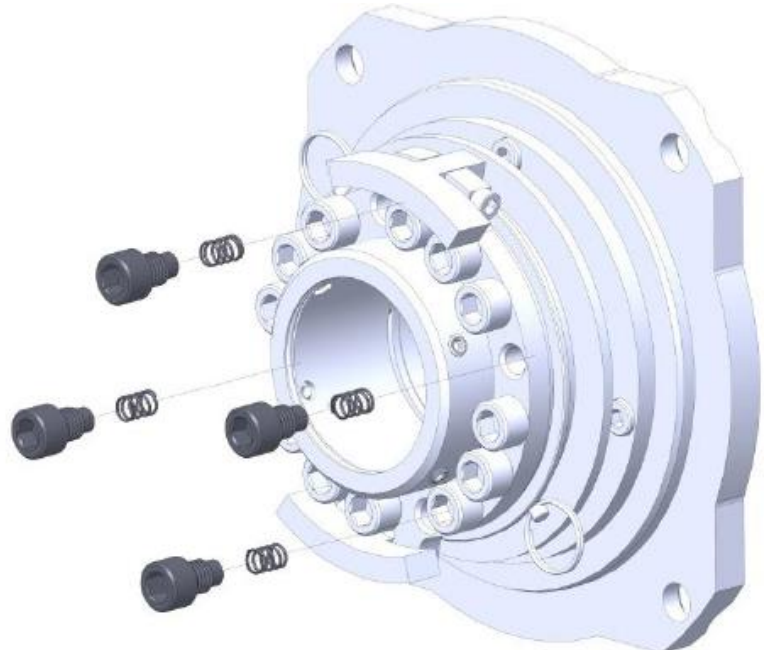

4.2 Adjusting Performance

The Solidlock seal may be fine-tuned for specific customer applications with the ability to change the seal opening and closing speeds. Spring bolts and springs may be added or removed to change the speed at which the seal faces open and close. Adding springs will make the seal close more quickly as the pump slows down but also take longer to open. Subtracting springs will make the seal open faster but take longer to close during shutdown. Shown below is the standard spring number by speed for the smallest size of the Solidlock seal. Follow the spring recommendations in **Section 4.0 Spring Number** or consult a Wilfley representative for additional opening and closing adjustment.

5.0 Rotary Seal Subassembly

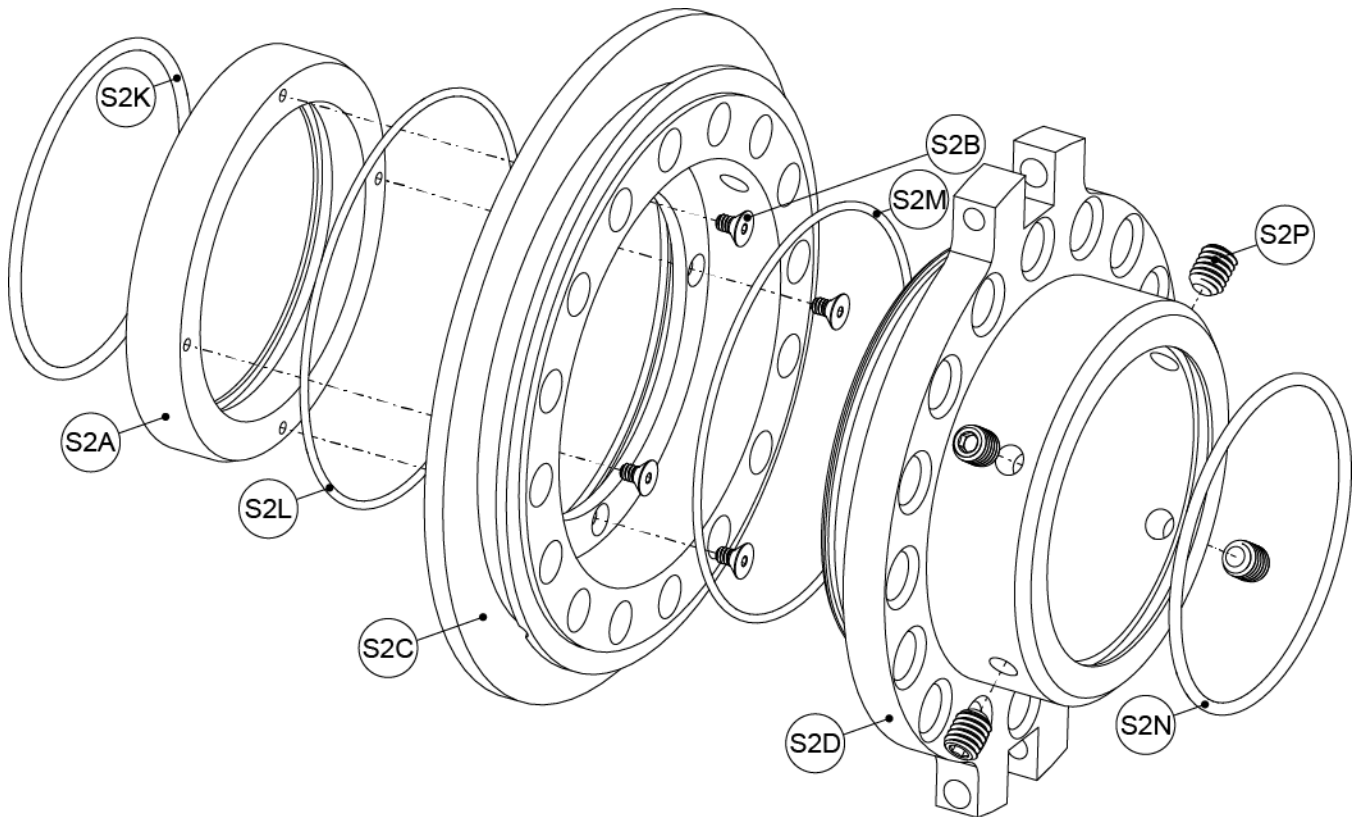

1. Install o-ring (S2K) into the rotary seal (S2A).
2. Install o-ring (S2L) into bore of the rotary seal carrier (S2C).
3. Insert rotary seal (S2A) into the rotary seal carrier (S2C) attaching them with bolts (S2B).
4. Insert o-ring (S2N) into the bore on the weight spider (S2D), and o-ring (S2M) onto the outer diameter groove of the weight spider (S2D).
5. Loosely install set screws (S2P) into the weight spider (S2D).
6. Insert weight spider (S2D) into the rotary seal carrier (S2C) in the orientation shown above, making sure the two sets of radial holes line up with each other.

Ref. #	QTY.	DESCRIPTION
S2A	1	Rotary Seal
S2B	4	Rotary Seal Bolt
S2C	1	Rotary Seal Carrier
S2D	1	Weight Spider
S2K	1	O-ring, Rotary Seal
S2L	1	O-ring, Rotary Seal Carrier
S2M	1	O-ring, Weight Spider
S2N	1	O-ring, Weight Spider to Shaft Sleeve
S2P	4	Shaft Sleeve Set Screw

5.1 Rotary Seal Assembly Step 2

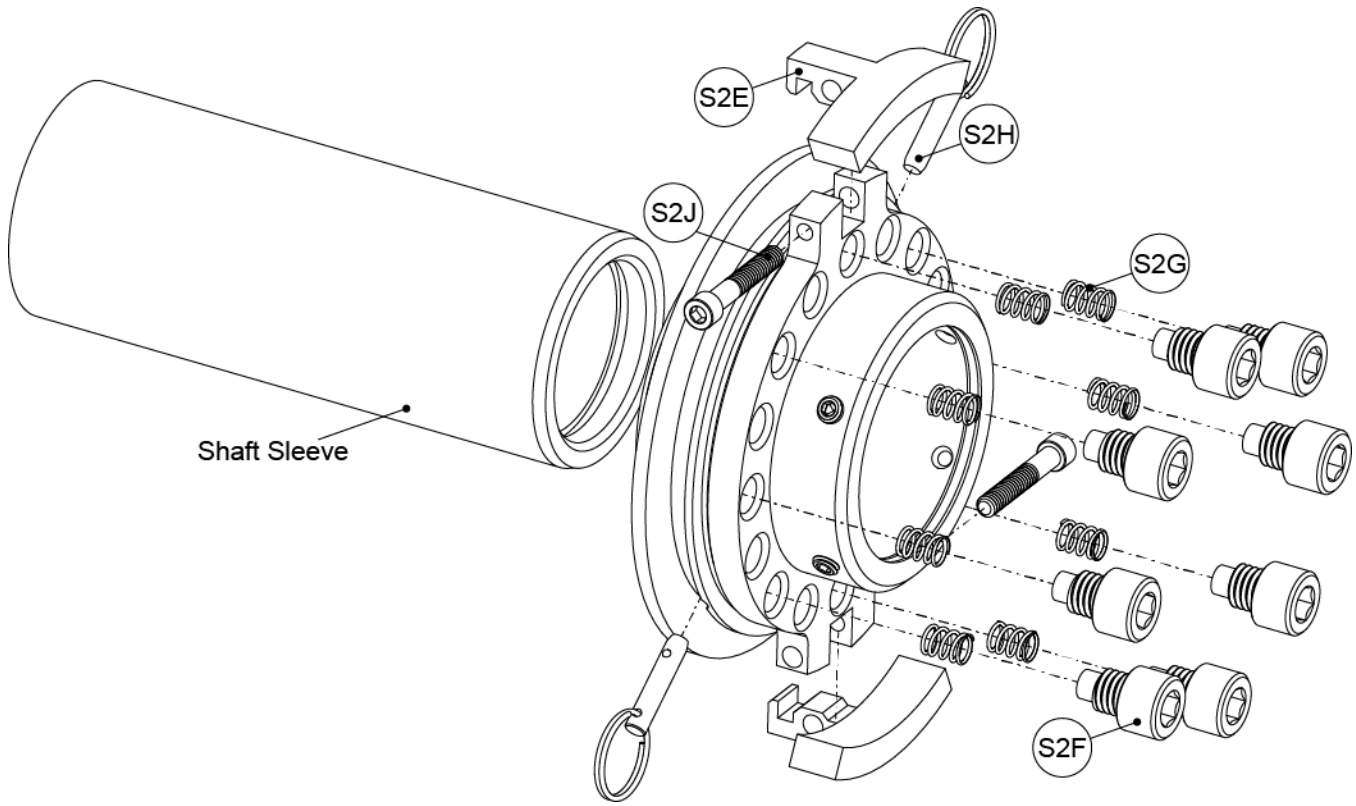

Shaft sleeve reference number varies by pump model:

MODEL	Ref. #
A7	39
A9	5A
AF	14
EMW [®]	14
HD	17
Kpro [®]	19C
S3	39

Ref. #	QTY.	DESCRIPTION
S2E	2	Weight
S2F	TBD*	Spring Bolt
S2G	TBD*	Spring
S2H	2	Pull Pin
S2J	2	Weight Bolt

*Refer to section 4.0 for quantities

1. Insert pins (S2H) to hold the rotary seal carrier (S2C) and weight spider (S2D) together.
2. Install weights (S2E) using the weight bolts (S2J) making sure the weights (S2E) are hooking onto the lip on the rotary seal carrier (S2C).
3. Install springs (S2G) and spring bolts (S2F), spacing them out evenly. Springs and spring bolts should be in an even pattern starting with one bolt directly under each weight.
4. Insert shaft sleeve into the subassembly.

6.1 Stationary Seal – A7/A9 Chemical Pump

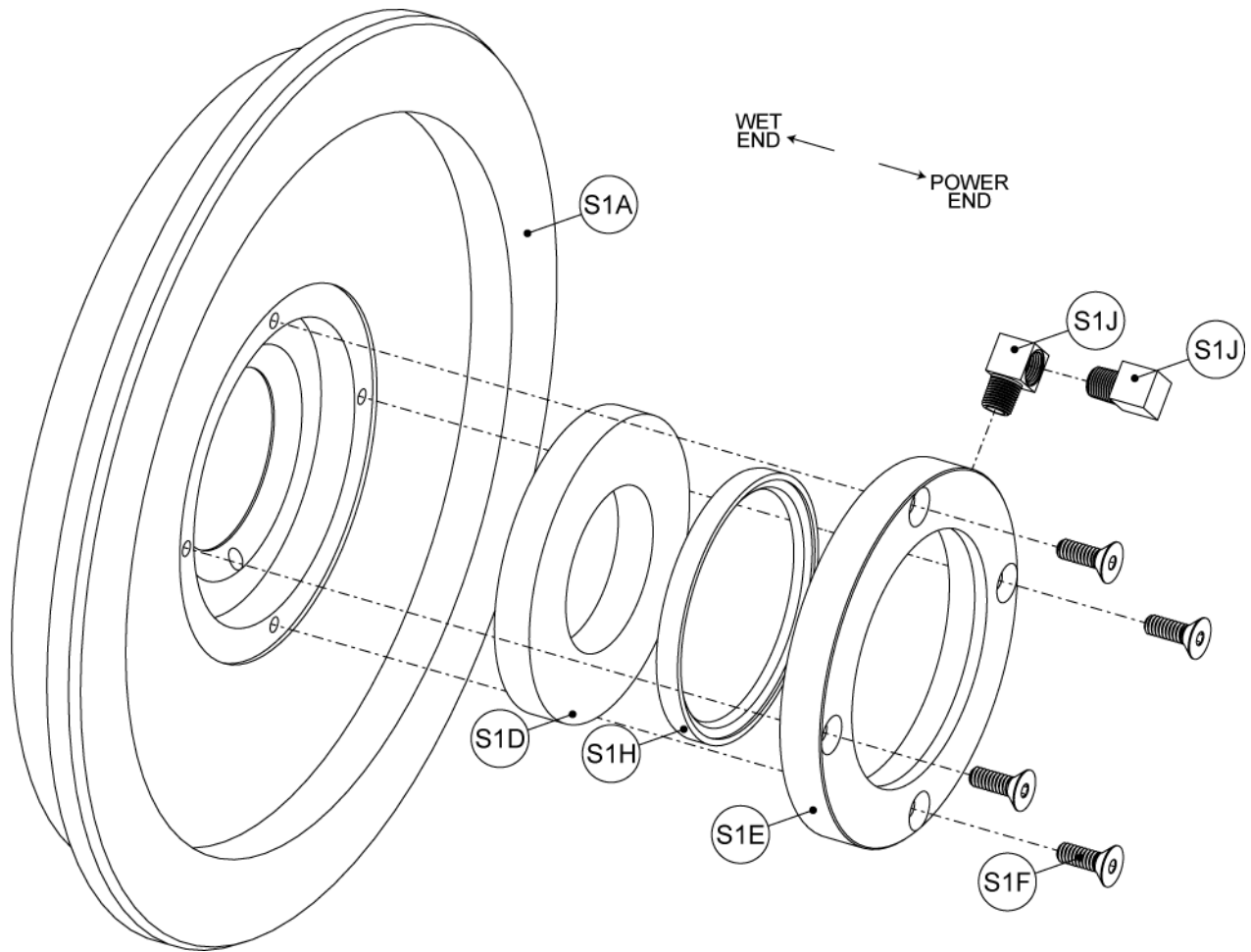

A7 / A9

1. Press lip seal (S1H) into the seal lock (S1E).
2. Insert elbows (S1J) into the seal lock (S1E).
3. Insert stationary seal (S1D) and seal lock (S1E) into the stationary seal housing (S1A). Secure in place with the stationary seal bolts (S1F). Tighten in a crisscross fashion.

Ref. #	QTY.	DESCRIPTION
S1A	1	Stationary Seal Housing
S1D	1	Stationary Seal
S1E	1	Seal Lock
S1F	4	Stationary Seal Bolt
S1H	1	Lip Seal
S1J	2	Elbow

Ensure lip seal (S1H) is installed in the correct direction:

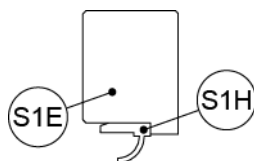

6.2 Stationary Seal - AF Chemical Pump

Ref. #	QTY.	DESCRIPTION
5*	1	Case Plate
67A	1	Case Plate Lab Ring Gasket
S1A	1	Lab Ring
S1D	1	Stationary Seal
S1E	1	Seal Lock
S1F	3	Stationary Seal Bolt
S1H	1	Lip Seal
S1J**	2	ELBOW

*Not included in retrofit kits

** Optional

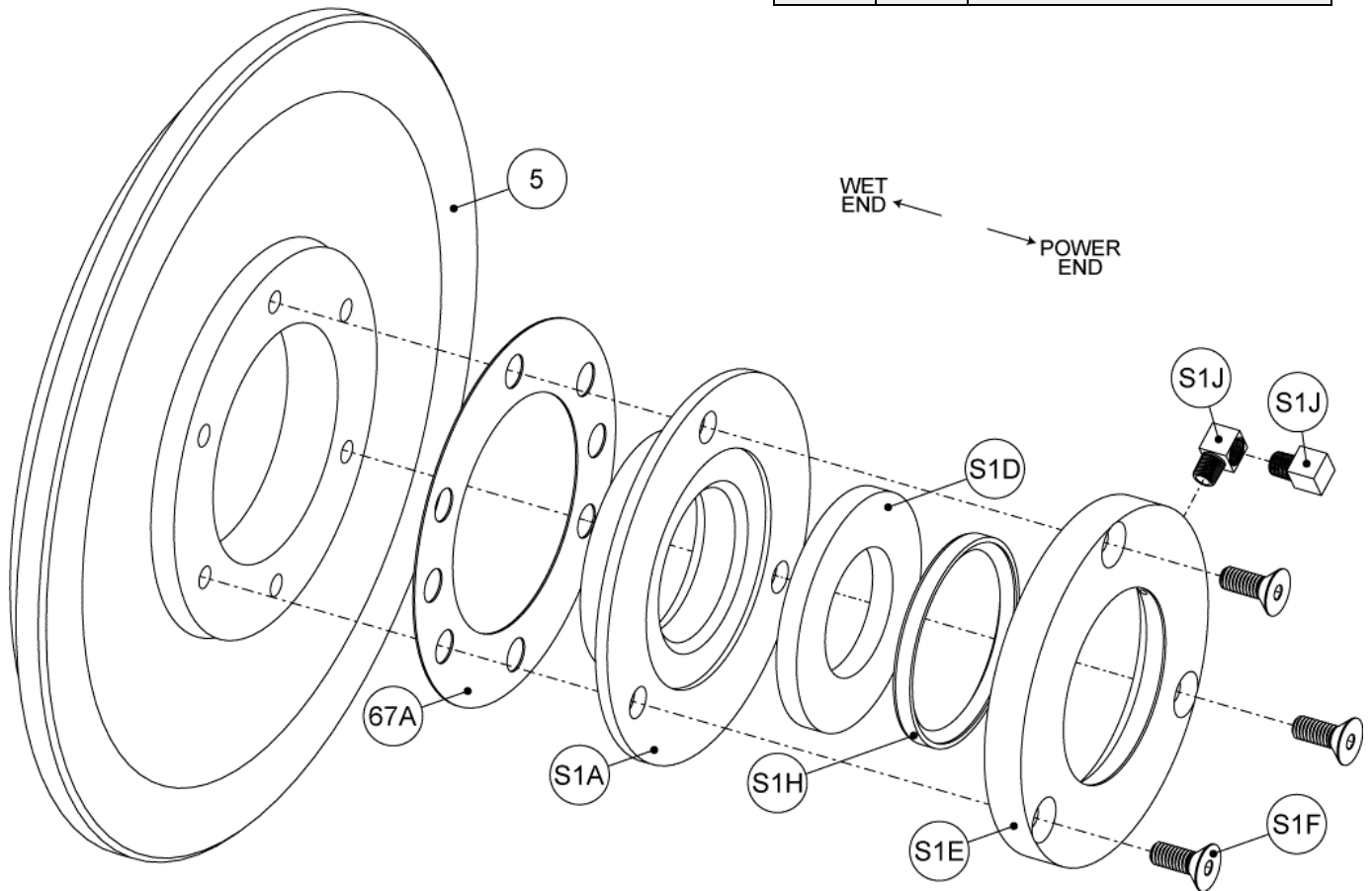

1. **Verify shaft is locked and that the impeller position will not move.**
2. This requires a spacer or washers to ensure that the Governor Sleeve (24) and Thrust Drive Sleeve (38) are spaced apart as far as possible. Contact your Wilfley representative for additional details on this.
3. Press lip seal (S1H) into the seal lock (S1E).
4. Insert elbows (S1J) into the seal lock (S1E).
5. Insert gasket (67A), lab ring (S1A), and stationary seal (S1D) into the case plate (5).
6. Secure in place with the seal lock (S1E) and bolts (S1F). Tighten in a crisscross fashion.

Ensure lip seal (S1H) is installed in the correct direction:

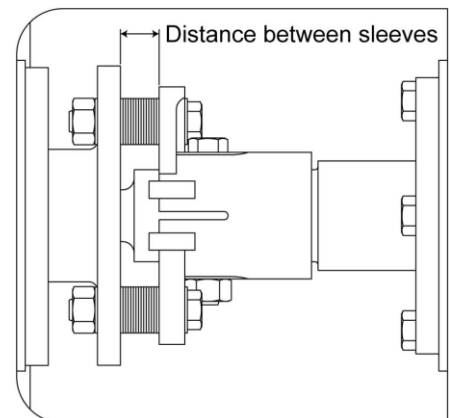
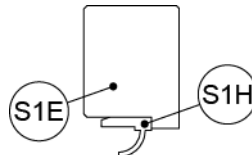

6.3 Stationary Seal - EMW® Slurry Pump

EMW® Slurry Pump (Standard Configuration)

ITEM NO.	QTY.	DESCRIPTION
S1A	1	Stationary Seal Housing
S1D	1	Stationary Seal
S1E	1	Seal Lock
S1F	4-6*	Stationary Seal Bolt

* Depends on pump size

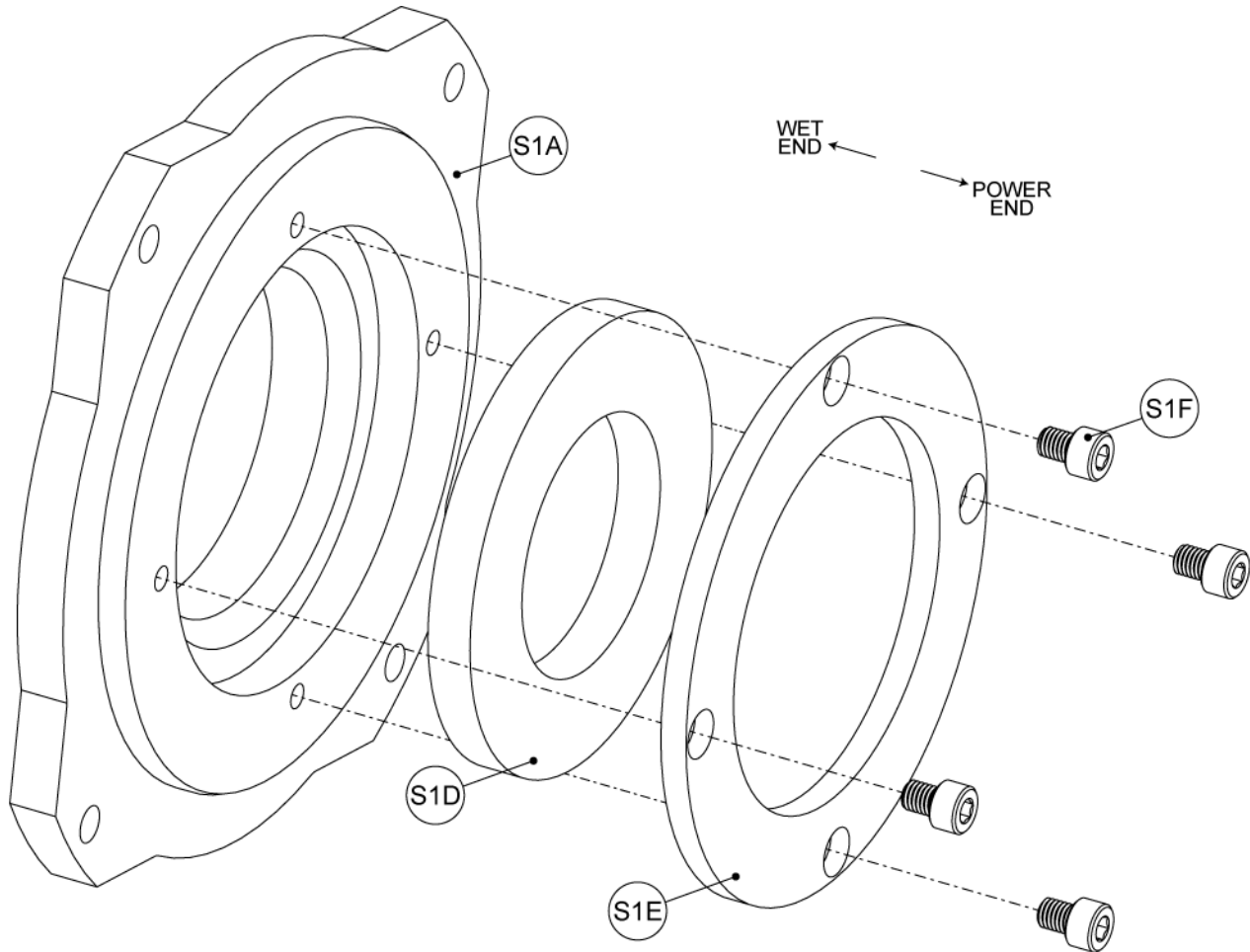

1. Insert stationary seal (S1D) into the stationary seal housing (S1A).
2. Secure in place with the seal lock (S1E) and bolts (S1F). Tighten in a crisscross fashion.

EMW® Slurry Pump (Purge Port Configuration)

*Depends on pump size

Ref. #	QTY.	DESCRIPTION
S1A	1	Stationary Seal Housing
S1D	1	Stationary Seal
S1E	1	Seal Lock
S1F	4-6*	Stationary Seal Bolt
S1H	1	Lip Seal
S1J	1	Elbow
S1L	1	Elbow

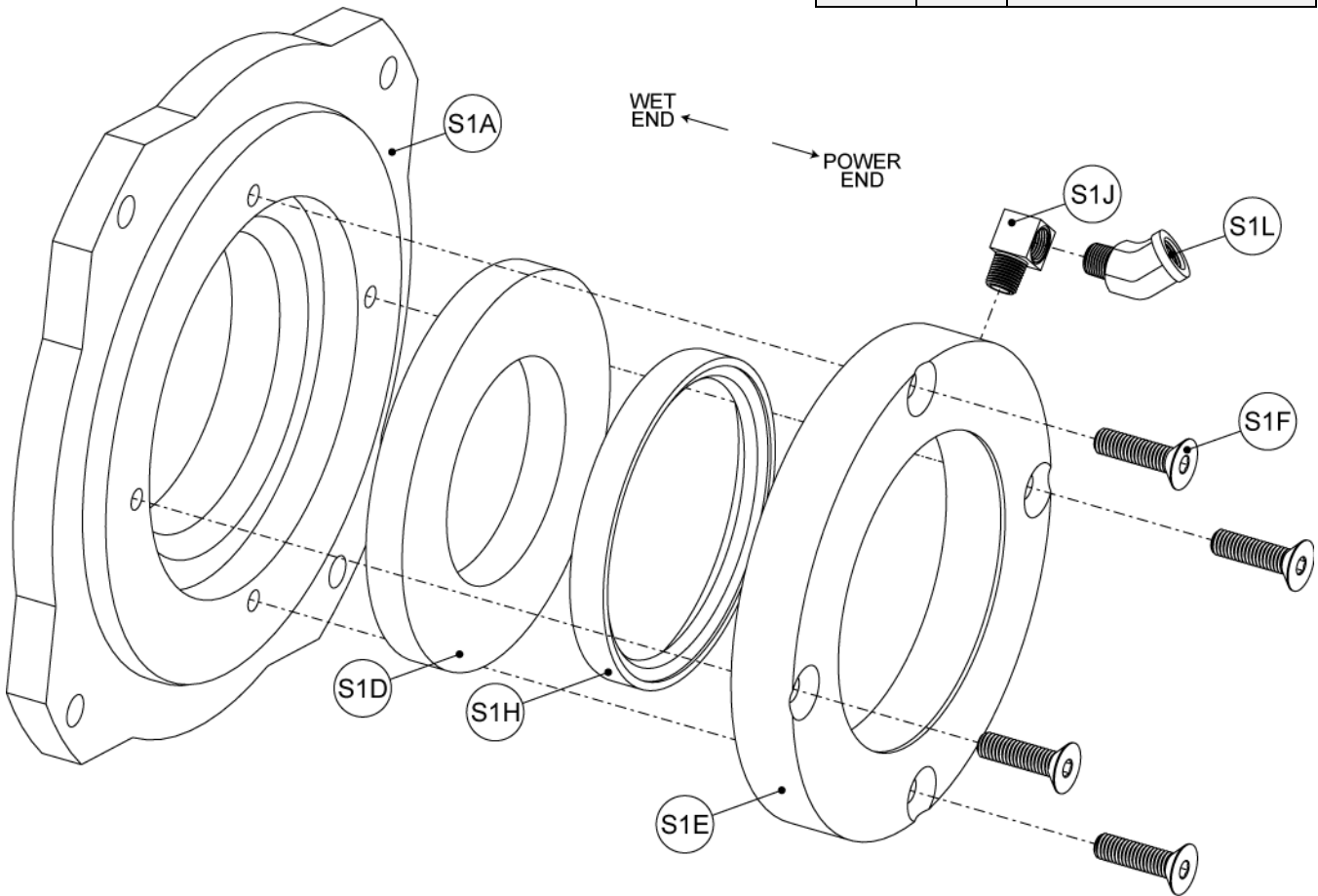

1. Press lip seal (S1H) into the seal lock (S1E).
2. Insert elbows (S1J & S1L) into the seal lock (S1E).
3. Insert stationary seal (S1D) into the stationary seal housing (S1A).
4. Secure in place with the seal lock (S1E) and bolts (S1F). Tighten in a crisscross fashion.

Ensure lip seal (S1H) is installed in the correct direction:

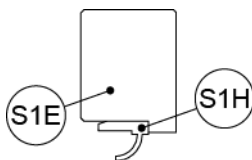

6.4 Stationary Seal - HD Slurry Pump

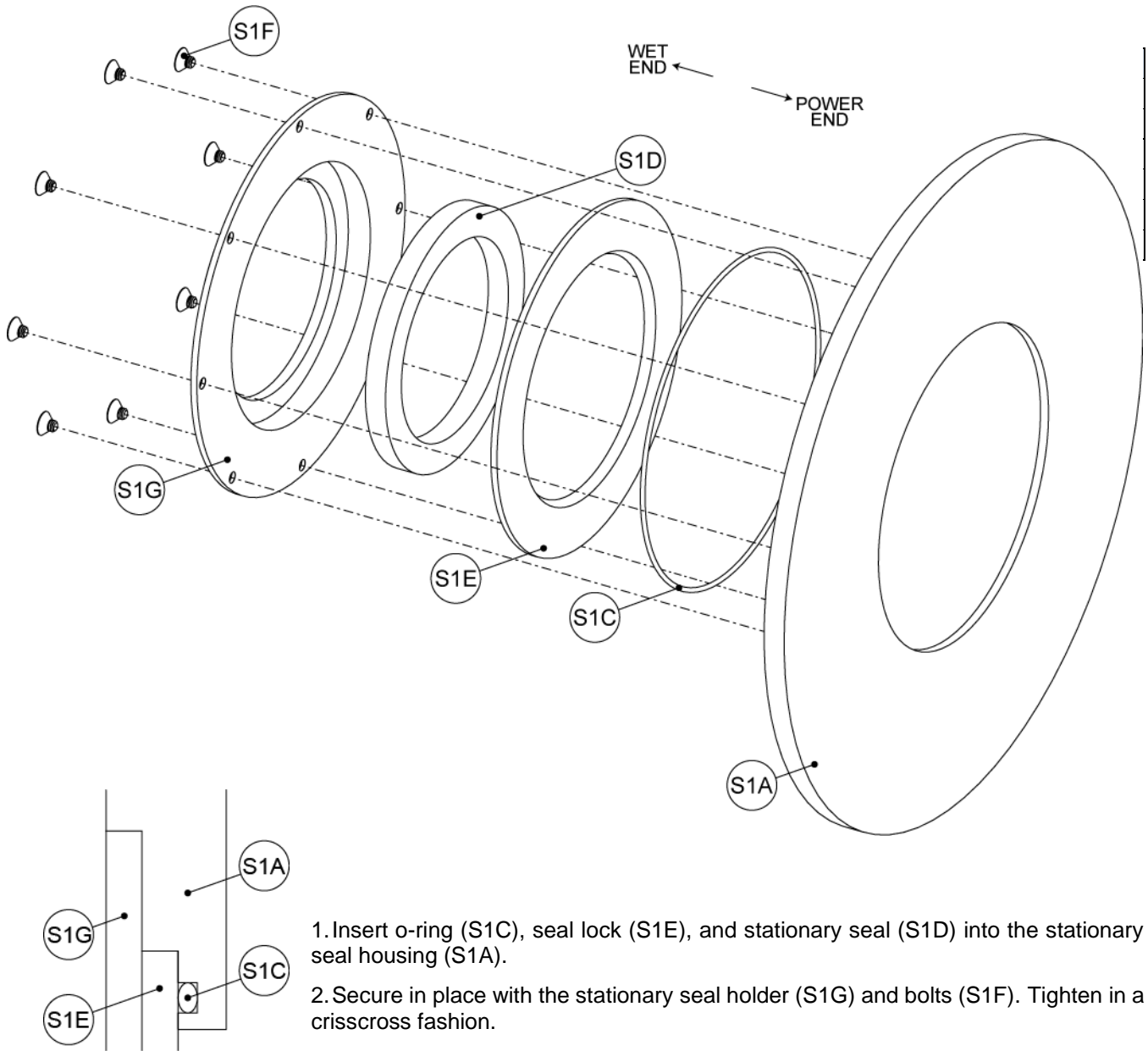

HD

6.5 Stationary Seal - Kpro® Slurry Pump

Kpro® Slurry Pump (Standard Configuration)

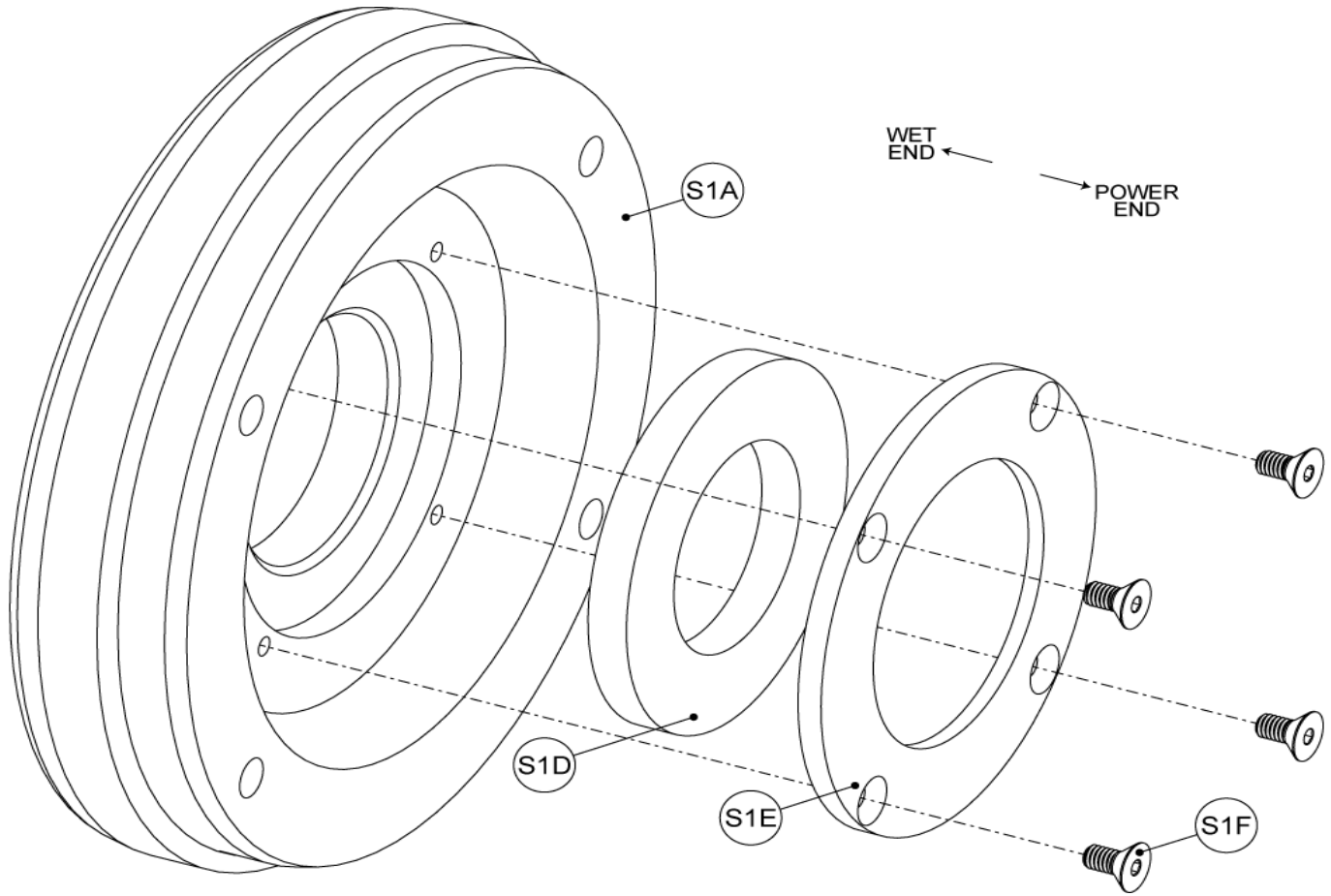

1. Insert stationary seal (S1D) into the stationary seal housing (S1A).
2. Secure in place with the seal lock (S1E) and bolts (S1F). Tighten in a crisscross fashion.

Ref. #	QTY.	DESCRIPTION
S1A	1	DESCRIPTION
S1D	1	Stationary Seal Housing
S1E	1	Stationary Seal
S1F	4	Seal Lock

Kpro®

Kpro® Slurry Pump (Purge Port Configuration)

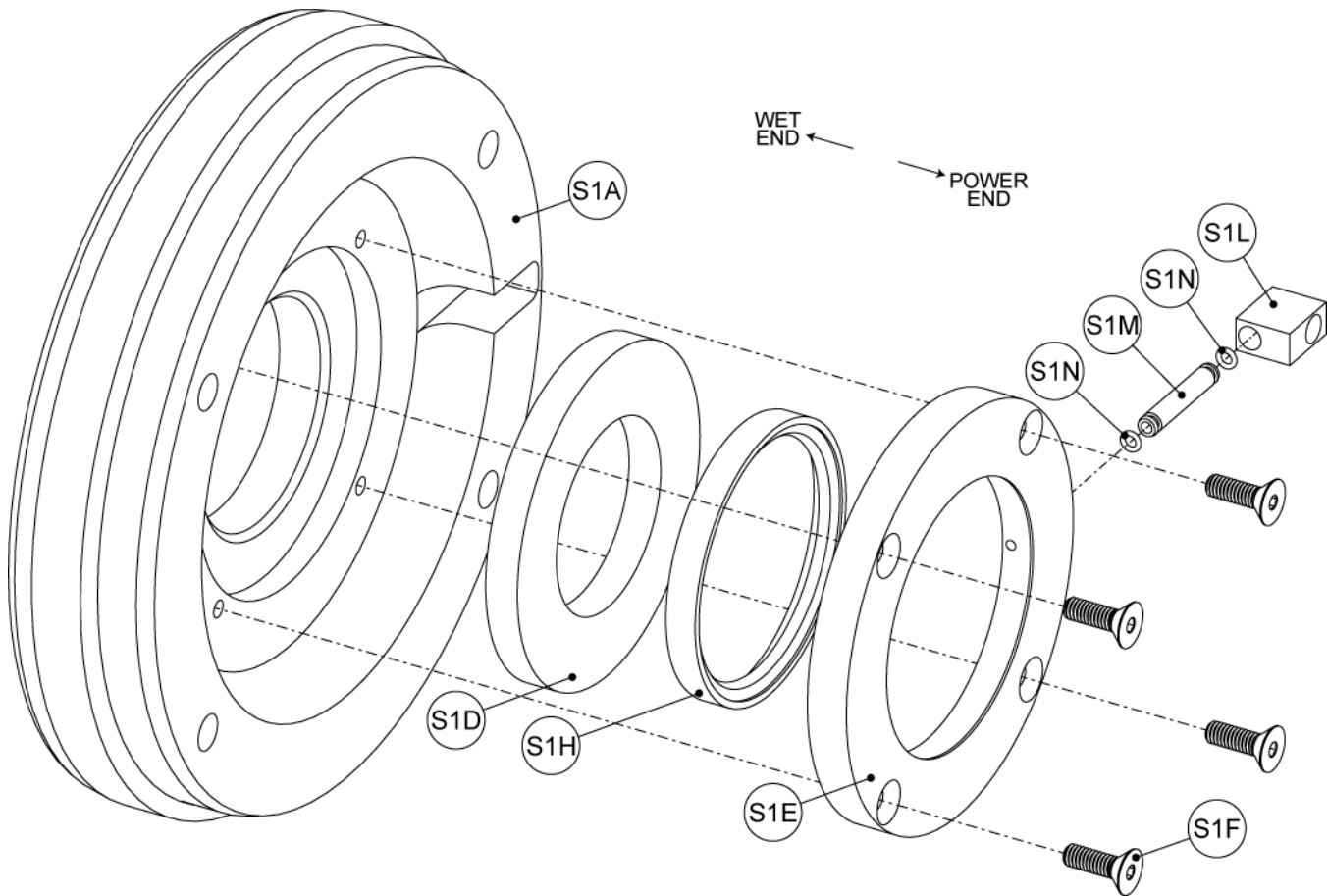

1. Press lip seal (S1H) into the seal lock (S1E).
2. Insert o-rings (S1N), transfer tube (S1M), and flush block (S1L) into the seal lock (S1E).
3. Insert stationary seal (S1D) into the stationary seal housing (S1A).
4. Secure in place with the seal lock (S1E) and bolts (S1F). Tighten in a crisscross fashion.

Ref. #	QTY.	DESCRIPTION
S1A	1	Stationary Seal Housing
S1D	1	Stationary Seal
S1E	1	Seal Lock
S1F	4	Stationary Seal Bolt
S1H	1	Lip Seal
S1L	1	Flush Block
S1M	1	Transfer Tube
S1N	2	O-Ring, Transfer Tube

Ensure lip seal (S1H) is installed in the correct direction:

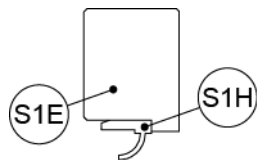

6.6 Stationary Seal - S3 Chemical Slurry Pump

S3 Chemical Slurry Pump (Standard Configuration)

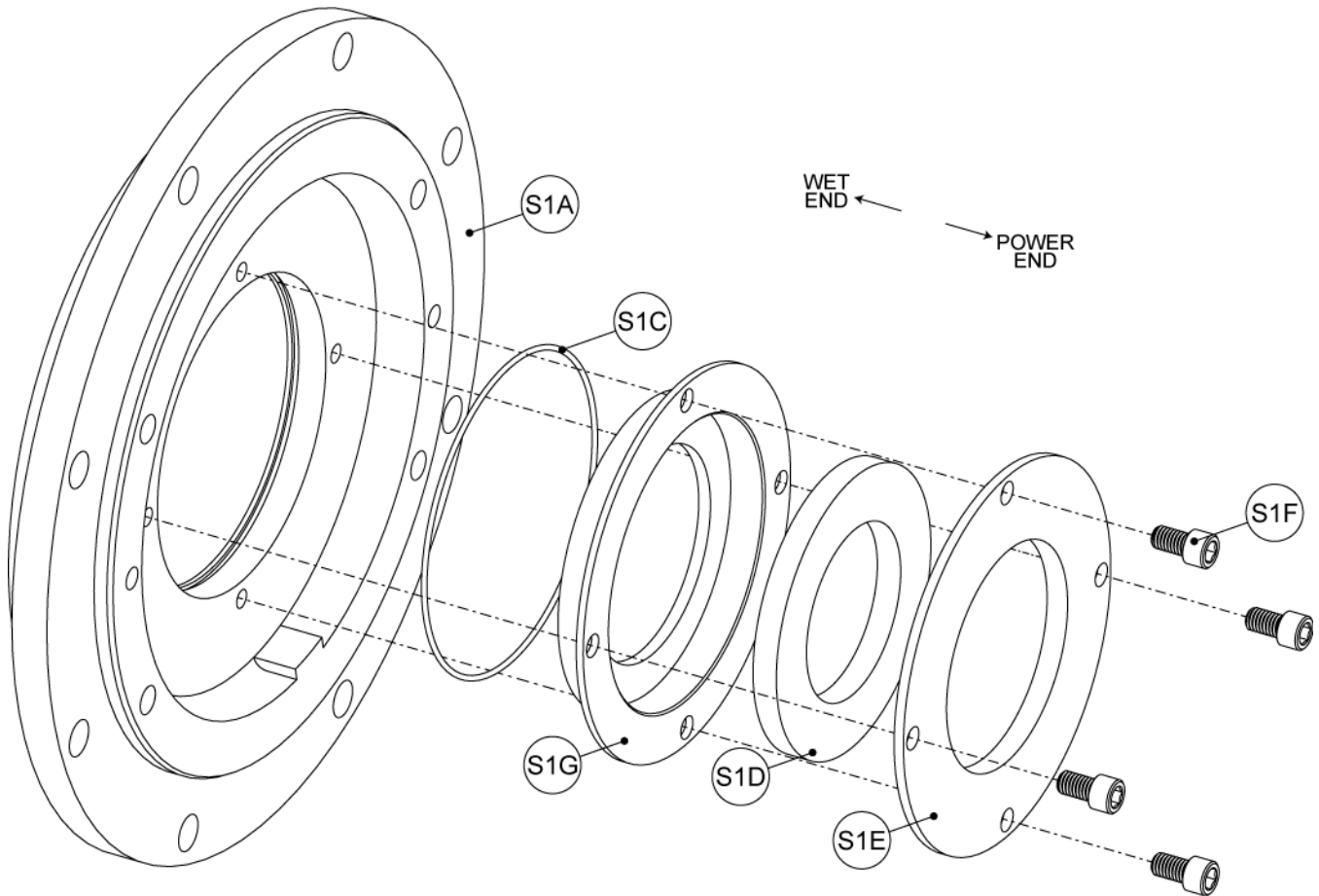

1. Insert o-ring (S1C), stationary seal holder (S1G), and stationary seal (S1D) into the stationary seal housing (S1A).
2. Secure in place with the seal lock (S1E) and bolts (S1F). Tighten in a crisscross fashion.

Ref. #	QTY.	DESCRIPTION
S1A	1	Stationary Seal Housing
S1C	1	O-Ring, Stationary Seal Housing
S1D	1	Stationary Seal
S1E	1	Seal Lock
S1F	4	Stationary Seal Bolt
S1G	1	Stationary Seal Holder

S3 Chemical Slurry Pump (Lip Seal Configuration)

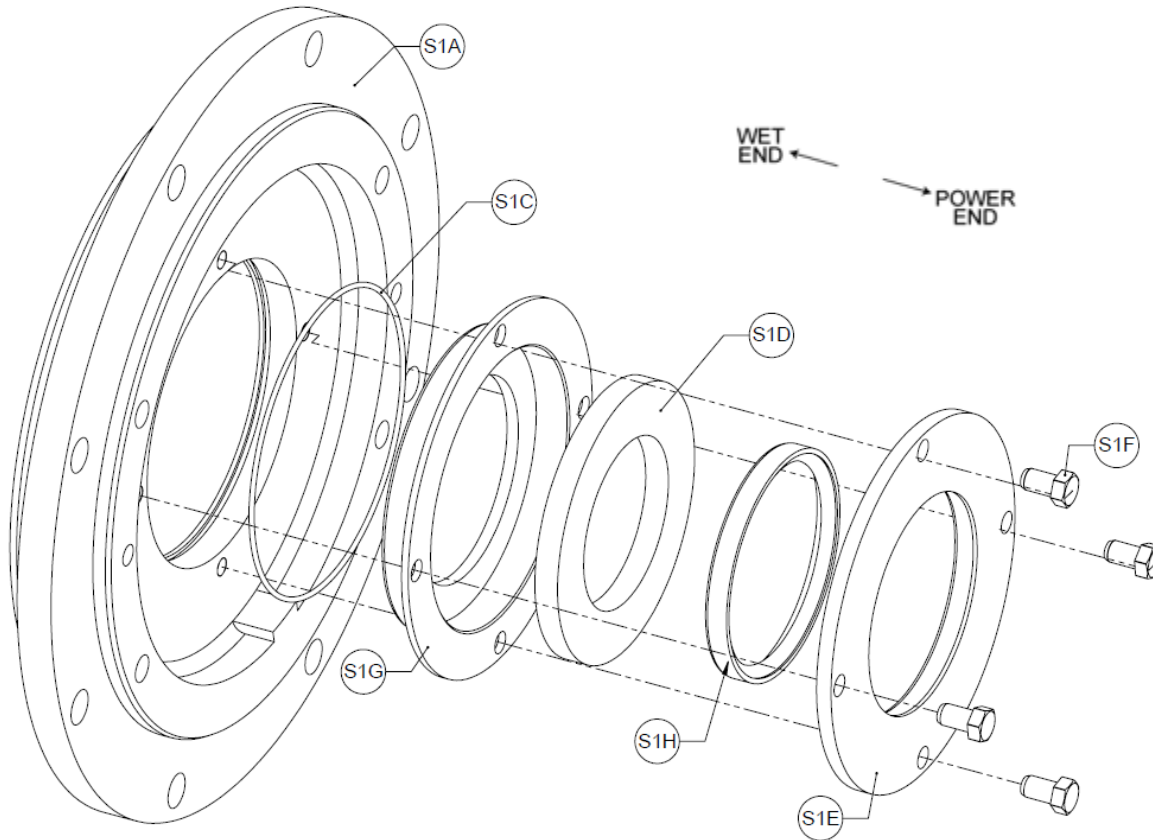

1. Press lip seal (S1H) into the seal lock (S1E).
2. Insert o-ring (S1C), stationary seal holder (S1G), and stationary seal (S1D) into the stationary seal housing (S1A).
3. Secure in place with the seal lock (S1E) and bolts (S1F). Tighten in a crisscross fashion.

Ref. #	QTY.	DESCRIPTION
S1A	1	Stationary Seal Housing
S1C	1	O-Ring, Stationary Seal Housing
S1D	1	Stationary Seal
S1E	1	Seal Lock
S1F	4	Stationary Seal Bolt
S1G	1	Stationary Seal Holder
S1H	1	Lip Seal

Ensure lip seal (S1H) is installed in the correct direction:

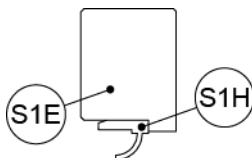

7.0 Recommended Spares

AR Wilfley recommends the following spares for startup and 2 year maintenance. The startup spares are meant to replace any o-rings or other parts that may be damaged disassembling and reassembling prior to or directly after startup as well as additional balls in the case that the seal opening speed needs to be modified. Two-year spares are meant to replace any additional hardware that might be corroded or worn over a short life of the pump. If the application is especially corrosive or erosive, it is recommended to also include any wetted parts for the two year service.

Ref #	Description	Startup	Year 2
S1B	Seal Housing Bolts		4
S1C	O-ring, Stationary Seal Housing	1	1
S1D	Stationary Seal		1
S1F	Stationary Seal Bolts		4 or 6
S2A	Rotary Seal		1
S2B	Rotary Seal Bolts		4
S2F	Spring Bolts	4	12
S2G	Springs	4	12
S2J	Weight Bolts		2
S2K	O-ring, Rotary Seal	1	1
S2L	O-ring, Rotary Seal Carrier	1	1
S2M	O-ring, Weight Spider	1	1
S2N	O-ring, Weight Spider to shaft Sleeve	1	1
S2P	Set Screws	-	4

8.0 Revision History

Revision	Description	Date
0	<ul style="list-style-type: none"> Initial Release 	Feb. 2015
1	<ul style="list-style-type: none"> Purge port configuration added to Kpro® and EMW® A7, A9, HD, and S3 product lines added 	July 2015
2	<ul style="list-style-type: none"> Removed sections regarding SolidLock® Lite Section 3.0 (Pump Assembly) added 	May 2017
3	<ul style="list-style-type: none"> Section 1.2 updated to show correct item number and description for case plate (5) and case plate lab ring gasket (67A) 	Oct. 2018
4	<ul style="list-style-type: none"> Corrected label for S3 (no purge port) Added lip seal configuration for S3 Added 1st spring bolt location under weight 	Feb 2020
5	<ul style="list-style-type: none"> Added Seal description Added bolt torqueing details Reorganized layout Added Spring Spacing section Added AF shaft lockout note Added recommended spares 	June 2020
6	<ul style="list-style-type: none"> Corrected elbow call out P.14 Added standard configuration to the EMW P.15 Added standard configuration to the Kpro P. 18 Added standard configuration to the S3 P. 20 	May 2021