

DryLock II Assembly for A9 Pumps

Performance Capabilities:

Temperature	-20°F to +400°F (-29°C to +204°C)
Static Pressure Rating	305 psi (2100 kPa)
Speed	900 - 3,600 RPM
Percent Solids by Weight	Up to 40%
Precision Controlled Seal Face Opening	0.020" (0.5mm) Actuation Travel

Varilip Seal Materials:

- 316SS with Carbon Filled Teflon
- 316SS with Glass Filled Teflon
- Hastelloy C with Carbon Filled Teflon (standard)
- Hastelloy C with Glass Filled Teflon

Style A1 (Varilip):

All chemical applications with solids
concentration up to 20%

Options:

- Seal housing with drip lip
- Opti-Expeller with labyrinth groove
- Expeller drain
- Steam jacket

Rotary Seal Face Materials:

- 316/304SS
- A20
- CD4/WCD4
- Hastelloy B, C, & G30
- Max 5/10
- Zirconia TTZ (for various acids)

Stationary Seal Face Materials:

- Carbon Filled PEEK (for various acids)
- Chemical Grade Carbon (for various acids)
- Glass Filled Teflon (for various acids)
- HIMOD 958 (for ammonium nitrate)
- Rulon A

Wiper Seal Materials:

- Carbon Filled Teflon with Kalrez
- Carbon Filled Teflon with Viton (standard)
- Glass Filled Teflon with Kalrez
- Glass Filled Teflon with Viton

Style A2 (Wiper Seal):

All chemical applications with solids
concentration above 20%

Options:

- Seal housing with drip lip
- Opti-Expeller with labyrinth groove
- Expeller drain
- Steam jacket

DryLock II Assembly for A9 Pumps

Style A1 & A2, All Frames

STYLE A1

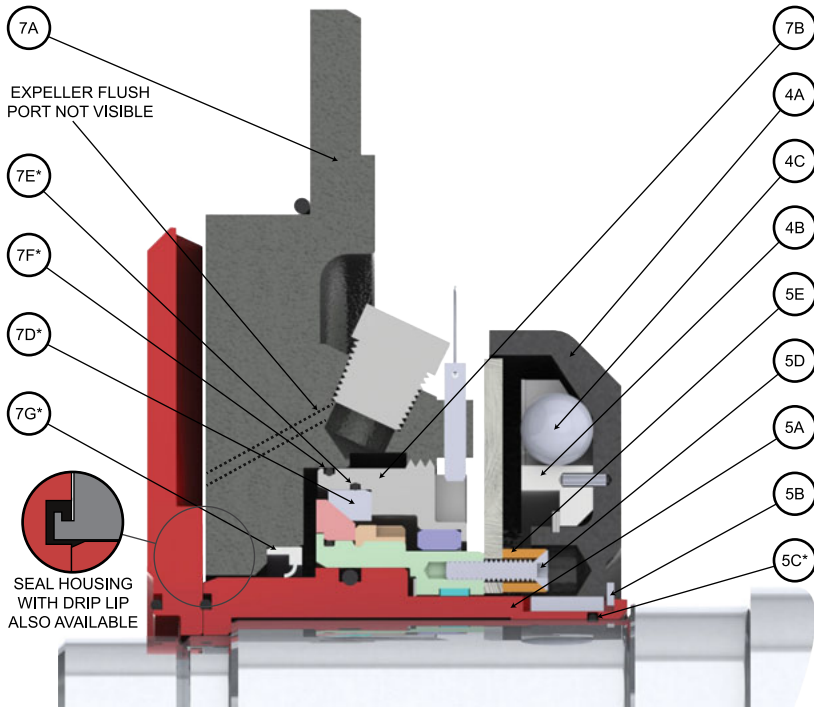

ITEM NO.	QTY.	DESCRIPTION
4A	1	BALL HOUSING
4B	1	BALL RETAINER
4C	3-18	BALLS
4D	1	RETAINING RING
4E	1	SPRING PIN
4F	1	KEY
5A	1	SHAFT SLEEVE
5B	1	RETAINING RING
5C*	1	O-RING, SHAFT SLEEVE
5D	4	DRIVE SCREW
5E	4	DRIVE SCREW SLEEVE
5F	1	ACTUATOR PLATE
5G	1	SEAL SLEEVE
5J	1	WAVE SPRING
5K*	1	SLIDE RING
5M	1	LOCKNUT
5N	1	ROTARY SEAL RING
5P*	1	O-RING, ROTARY SEAL
5Q*	1	O-RING, SEAL SLEEVE
5R*	2	O-RING, EXPELLER
7A	1	SEAL HOUSING
7B	1	SEAL CARTRIDGE
7C	1	DISASTER BUSHING
7D*	1	STATIONARY SEAL RING
7E*	1	O-RING, STATIONARY SEAL RING
7F*	1	O-RING, CARTRIDGE
7G*	1	VARILIP (A1) OR WIPER SEAL (A2)
7J	1	QUICK RELEASE PIN
10*	1	O-RING, SEAL HOUSING
14	1	OPTI-EXPELLER

STYLE A2

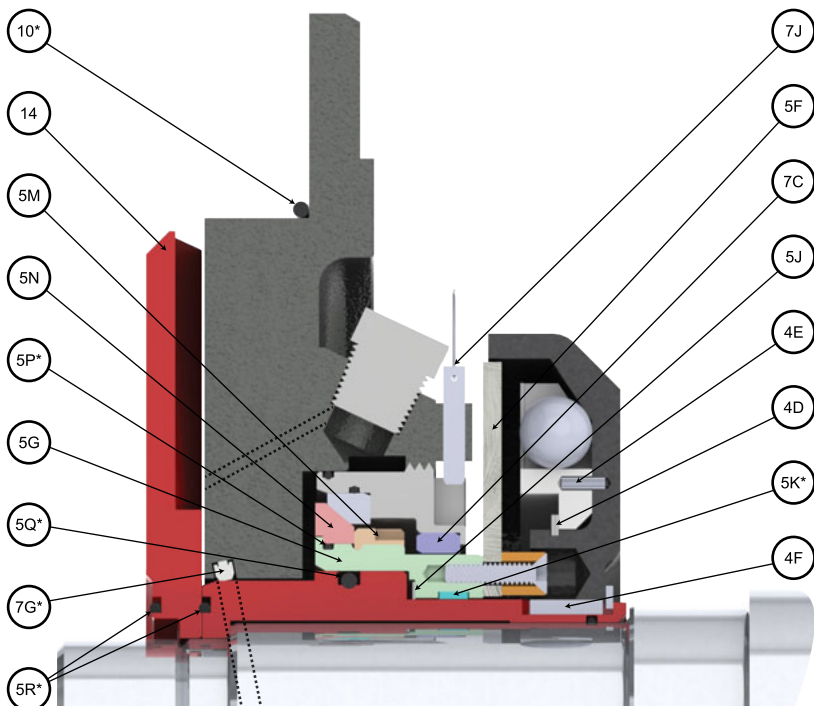

NOTES:

- DRAWING IS NOT TO SCALE AND REPRESENTS ONLY THE GENERAL ARRANGEMENT OF PARTS.
- ITEMS MARKED WITH * ARE RECOMMENDED SPARE PARTS.

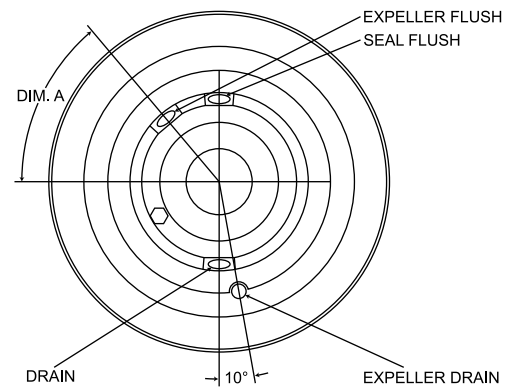

	DIM. A
FRAME 1	30 Deg.
FRAME 2	50 Deg.
FRAME 3	15 Deg.
FRAME 4	20 Deg.

WILFLEY

DR2A9-03-0212